

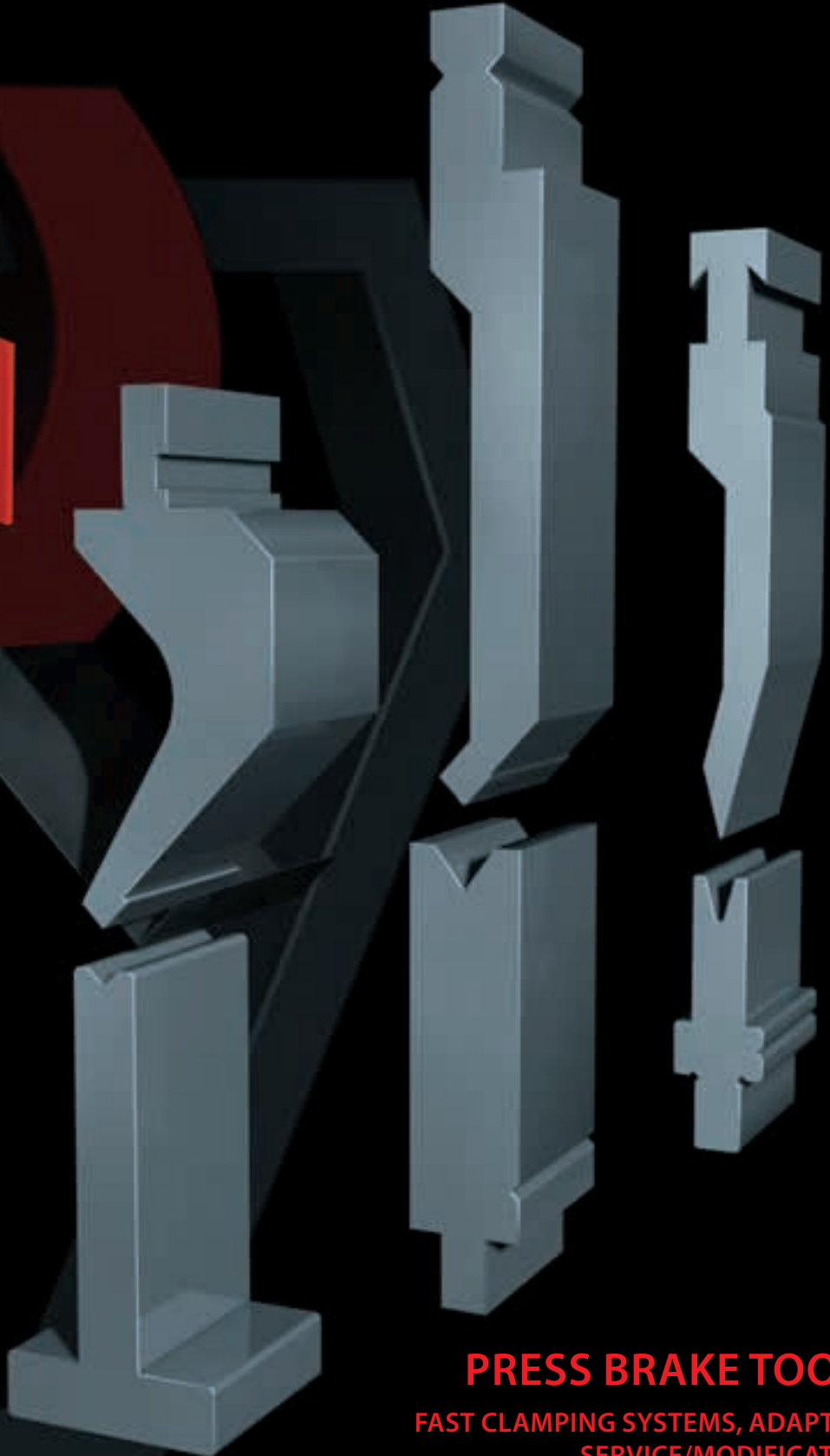

**ROLLERI®**

**PROFESSIONAL  
BENDING**

**DIRECTLY  
FROM THE  
MANUFACTURER!**



**PRESS BRAKE TOOLS**

**FAST CLAMPING SYSTEMS, ADAPTERS,  
SERVICE/MODIFICATION,  
SHEAR BLADES, ACCESSORIES**

## ROLLERI

### WELCOME ...

... to the new Rolleri catalogue!

Rolleri is one of the few **real manufacturers** of press brake tools – not a reseller and not a dealer. Therefore we emphasize great importance as being **producer** of press brake tools to bring you further advantages.

- no margin division
- direct access to the production
- direct communication, not only by specific and special bending tools.
- Competent and truthful statement about prices and delivery times – without tedious queries!

**Convince yourself of our service and quality of tools!**



### THE COMPANY

Since 1987 we have been producing standard and special tooling. The family owned company (Francesco and Marco Rolleri) can nowadays be considered one of the largest press brake tooling manufacturers in Europe. We are internationally available with our branches Rolleri Brasil, Rolleri USA, Rolleri India, Rolleri Deutschland GmbH, Rolleri China, Rolleri Ukraine and Rolleri Benelux, for you to utilize our global experience and footprints.

We offer fast and reliable service through our partners in all of Europe. In 2012, we have completely restructured our facilities internally. The focus of direct sales structures in the individual countries has greatly improved. We present to you, a new expanded portfolio, a significantly enlarged stock, new corporate design, and a completely new catalog that you now hold in your hands. Our promise to an alternative for you Worldwide.

### THE TEAM

The Rolleri team is made up of all ages. We are innovative, dynamic and experienced, with consistency and harmony. Our mission is to bring you the best results in tool production. At Rolleri teamwork is the key to achieve outstanding customer service, research and development, great warehouse efficiency, and vast productivity.

The exceptional atmosphere in our facilities always has a positive impact on our products.



### Rolleri Videos

Company Presentation  
[www.rolleritools.com/videos/company-rolleri](http://www.rolleritools.com/videos/company-rolleri)

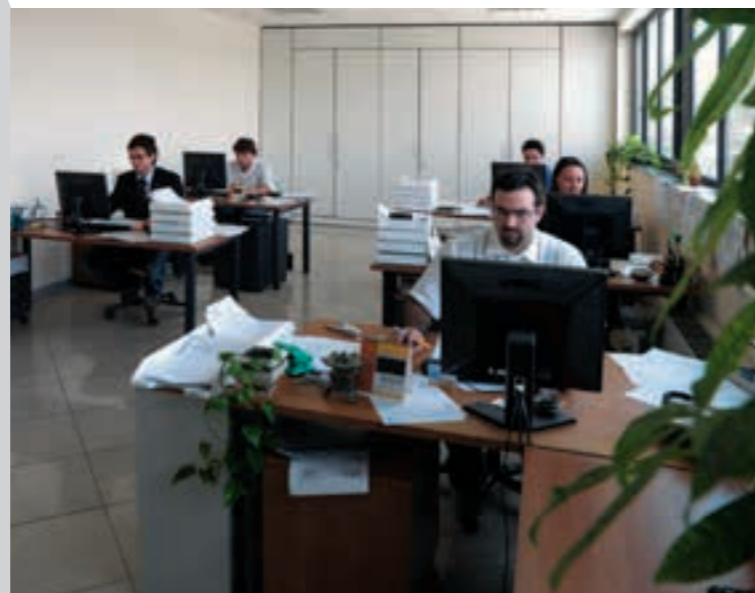

### THE PRODUCTION

All production phases are certified and up to quality check standards and safety regulations. Thereby we guarantee you consistent high quality with modern CNC-machines.

All tools are laser marked with a serial number. Thus, allowing every single tool to be identified and easily tracked for reproduction.

This is what we call accurate repetition.



### THE WAREHOUSE

We at Rolleri, have a wide stock ranging over more than 20,000 press brake tools. Therefore, we hold one of the largest in house stocks in all of Europe. For you this means a vast amount of tools to choose from ready to be shipped all around the world.



Look for this symbol in the catalogue!



### THE SERVICE

We understand that finding the right tool for the right application is of your importance. Thus, we have invested hard work into our quality service:

- Consulting,
  - Technical assistance,
  - Training for your bending specialists,
- this is our daily business bringing you great support!

Check out our **website: [www.rolleritools.com](http://www.rolleritools.com)**



... also this is customer service: Rolleri provides you with immediate production after a purchase has been made to ensure the fastest delivery time!

THE CONSTRUCTION

Besides constructing many special tools, our research and development team also innovates special clamping systems which increases your productivity. Technicians and Engineers develop for you solutions which are economic and practical.

We work with highly complex 3D simulation models and are capable to create bending examples of various profiles.

Inquire with us today!



THE RAW MATERIAL

The raw material is obtained from qualified suppliers which compose the chemical formulas according to international standards. Therefore, guaranteeing high resilience and tensile strength.



THE QUALITY

Rolleri ISO 9001:2008 certified. To be your choice supplier means much more to us; together we can find the best and most economic tool and develop a vast number of bending solutions. We also offer training for your employees in the bending department. These are qualities, where we are glad to assist you along with our extravagant number of bending products.

THE PRESS BRAKE TOOLS

Rolleri manufactures all tools in their own production facilities. We put great importance into our precision grinding, guaranteeing accurate reproduction of tools, exact concurrency. We induction harden all tools at 54-60 HRC to get the best results for your punches and dies. Each tool is subjected to quality control and then provided with a serial number to simplify and guarantee tracking.



THE QUALITY CONTROL

An extra quality control department reviews and tests every single tool after a complete production cycle.

Every tool is given a serial number and batch number, after being carefully examined. This process guarantees a 100% retracing possibility of the tool.

Of course Rolleri also guarantees accurate reproduction, high-quality material, induction hardening, and precision grinding.



INNOVATIONS

Rolleri produces for many press brake manufacturers the clamping systems - whether they are hydraulic, pneumatic, or manual.

Our new QuickLock-System, compatible for our Rolleri Type R2 or our new ROL 100 for Rolleri Type R1, are all new developments from Rolleri which are manufactured in our production facilities.

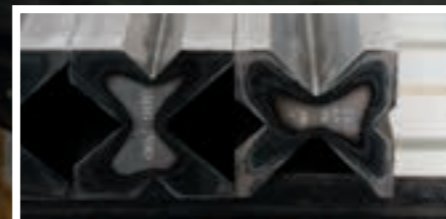

## ROLLERI MARK FREE BENDING

Prevention of Bending Marks	224
Bending Foil Holder/Tensioner	224
Bending Foil	225
PU-Holder and PU-Upholstery	226 - 227
Synthetic Dies	228 - 229



## ROLLERI MARK FREE BENDING

### Prevention of Bending Marks

One of the challenges of bending is to prevent the profile of having bending marks, such as; scratches and abrasions on the surface areas.

Especially of Profile made of:

- Stainless Steel
- Aluminium
- painted metal panels

It is often the case of a line building from the contact of the sheet metal with the die. This is the cause of friction of sheet metal on small radius.

In order to prevent this markings, the following solutions are possible:

- Bending Foil
- PU-Upholstery
- Plastic Dies
- enlarged opening radius on special T-Dies



### Our Advantages – Your Convenience

- Prevention of scratches and abrasions on bent sheet metals
- No post-processing necessary, therefore time and cost saving
- No contamination of bended pieces
- increases the product quality
- easy handling

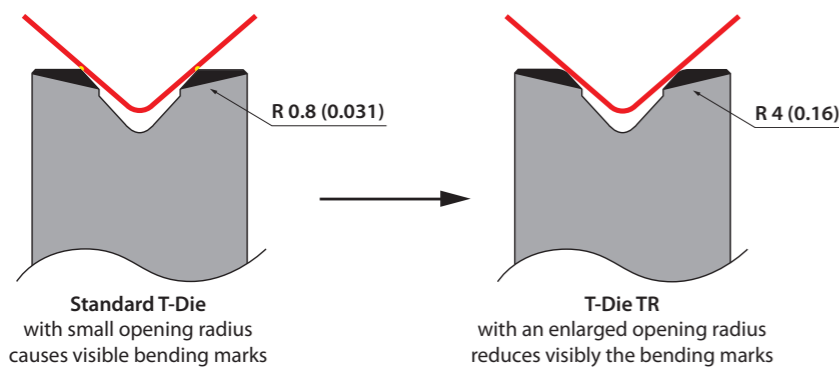

T-Dies (TR) with an enlarged opening radius for the prevention of bending marks see pages 54-55, 60-61

### Bending Foil - Holder / Tensioner

CT



## ROLLERI MARK FREE BENDING

### Bending Foil



### Our Advantages – Your Convenience

- easy handling
- can be used flexibly
- Prevention of Bending Marks
- decrease of post-processing of bent parts
- no contamination of the material
- increased product quality



Bending Foil:  
Practical, easy and economic!

### ROLFILM



Model	Thickness (mm)	Thickness (in)	Width (mm)	Width (in)	Length (m)	Length (in)
Rolfilm 3-0.4-100	0.4	0.016	100	3.94	3	118.11
Rolfilm 10-0.4-100	0.4	0.016	100	3.94	10	393.70
Rolfilm 20-0.4-100	0.4	0.016	100	3.94	20	787.40
Rolfilm 30-0.4-100	0.4	0.016	100	3.94	30	1181.10
Rolfilm 3-0.4-150	0.4	0.016	150	5.91	3	118.11
Rolfilm 10-0.4-150	0.4	0.016	150	5.91	10	393.70
Rolfilm 20-0.4-150	0.4	0.016	150	5.91	20	787.40
Rolfilm 30-0.4-150	0.4	0.016	150	5.91	30	1181.10
Rolfilm 3-0.6-150	0.6	0.024	150	5.91	3	118.11
Rolfilm 10-0.6-150	0.6	0.024	150	5.91	10	393.70
Rolfilm 20-0.6-150	0.6	0.024	150	5.91	20	787.40
Rolfilm 30-0.6-150	0.6	0.024	150	5.91	30	1181.10
Rolfilm 3-0.6-200	0.6	0.024	200	7.87	3	118.11
Rolfilm 10-0.6-200	0.6	0.024	200	7.87	10	393.70
Rolfilm 20-0.6-200	0.6	0.024	200	7.87	20	787.40
Rolfilm 30-0.6-200	0.6	0.024	200	7.87	30	1181.10
Rolfilm 3-2-150	2.0	0.079	150	5.91	3	118.11
Rolfilm 10-2-150	2.0	0.079	150	5.91	10	393.70
Rolfilm 20-2-150	2.0	0.079	150	5.91	20	787.40
Rolfilm 30-2-150	2.0	0.079	150	5.91	30	1181.10



### Rolleri Videos

mark free bending:  
[www.rolleritools.com/videos/mark-free-bending](http://www.rolleritools.com/videos/mark-free-bending)



# ROLLERI MARK FREE BENDING

## PU-Holders and PU-Upholstery

### MPG25

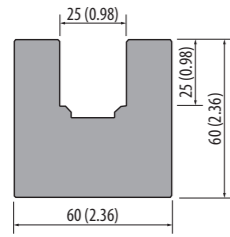

835 mm	32.87 in	18.5 kg
415 mm	16.34 in	9.2 kg

C45: 560-710 N/mm<sup>2</sup>



### MPG50

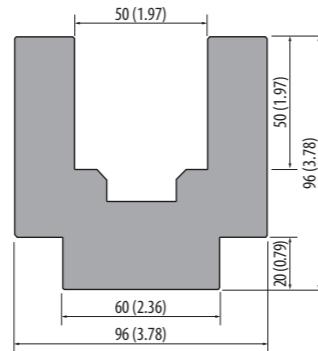

835 mm	32.87 in	44.0 kg
415 mm	16.34 in	22.0 kg

C45: 560-710 N/mm<sup>2</sup>



### GM 25x25



835 mm	32.87 in	0.6 kg
415 mm	16.34 in	0.3 kg

polyurethane



### GM 50x50

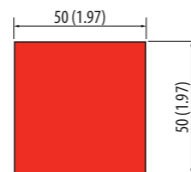

835 mm	32.87 in	2.5 kg
415 mm	16.34 in	1.2 kg

polyurethane



### GMF 25x25x10

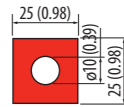

835 mm	32.87 in	0.6 kg
415 mm	16.34 in	0.3 kg

polyurethane



### GMF 50x50x25

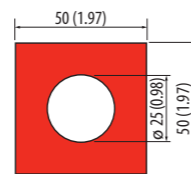

835 mm	32.87 in	2.5 kg
415 mm	16.34 in	1.2 kg

polyurethane



### PSTCON

cover plate	Model	A (mm)	A (in)	R (mm)	R (in)	Weight
	PSTCON25	58	2.28	58	2.28	1.2 kg
	PSTCON50	108	4.25	75	2.95	0.6 kg
	PSTCON75	123	4.84	80	3.15	0.8 kg
	PSTCON100	153	6.02	80	3.15	1.0 kg

C45: 560-710 N/mm<sup>2</sup>

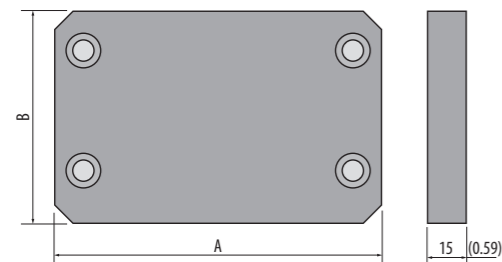

### Mounting example

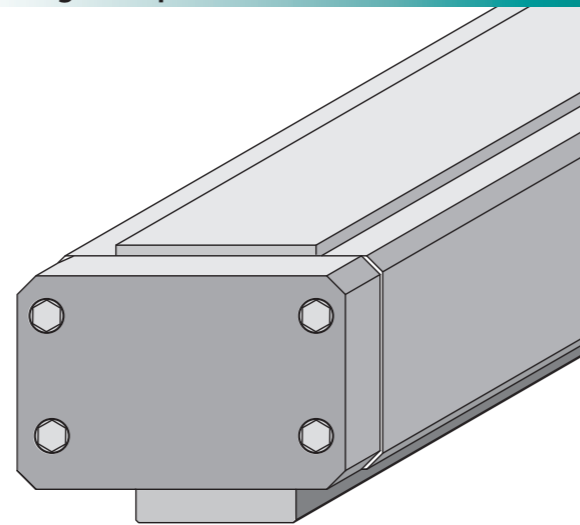

# ROLLERI MARK FREE BENDING

## PU-Holders and PU-Upholstery



### MPG75

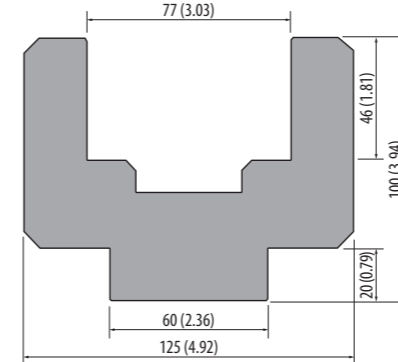

835 mm	32.87 in	46.0 kg
415 mm	16.34 in	22.5 kg

C45: 560-710 N/mm<sup>2</sup>



### Mounting example

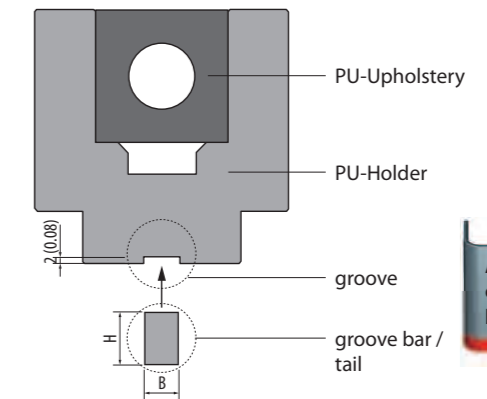

Also mountable on other press brakes!

### GM 75x50



835 mm	32.87 in	3.5 kg
415 mm	16.34 in	1.7 kg

polyurethane



### GMF 75x50x20

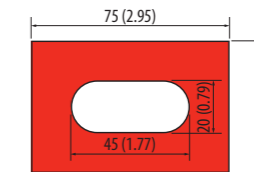

835 mm	32.87 in	3.5 kg
415 mm	16.34 in	1.7 kg

polyurethane



### MPG100

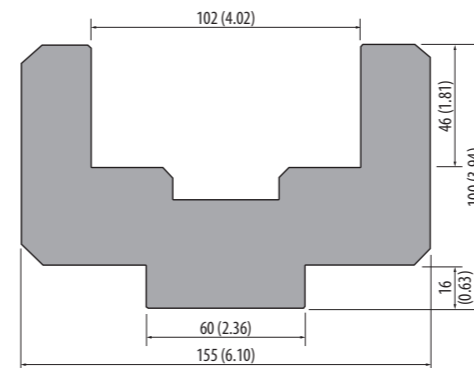

835 mm	32.87 in	55.0 kg
415 mm	16.34 in	27.5 kg

C45: 560-710 N/mm<sup>2</sup>



PU-Upholstery are suitable for radius- and U-profile bendings, etc.

### GM 100x50



835 mm	32.87 in	5.0 kg
415 mm	16.34 in	2.5 kg

polyurethane



### GMF 100x50x20

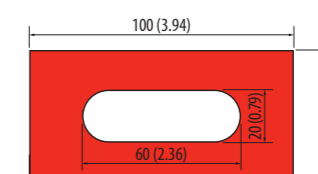

835 mm	32.87 in	3.0 kg
415 mm	16.34 in	2.2 kg

polyurethane



# ROLLERI MARK FREE BENDING

## Synthetic Dies

### Our Advantages – Your Convenience

- easy Handling
- faster and easier exchange of plastic dies
- prevention of bending marks
- decrease of post-processing of bent pieces
- no contamination of the materials
- increased product quality

### Mounting example

Synthetic dies will be adjusted into the housing and secured with bolted screws.

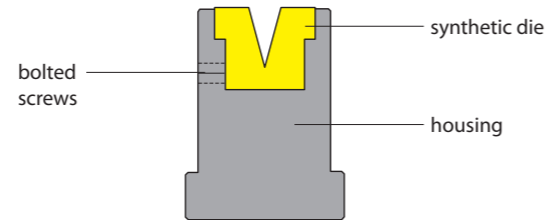

### TN80.14 1000 kN/m max.

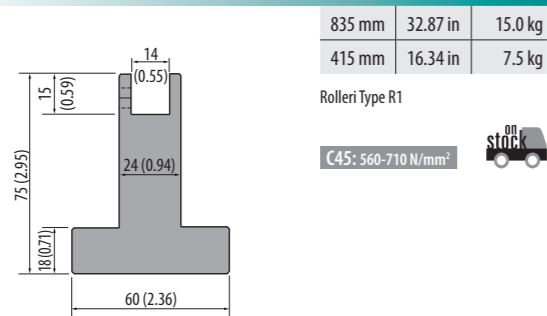

### INS14... 200 kN/m max.

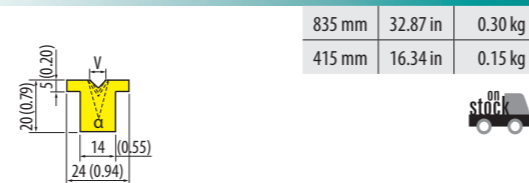

Model	α	V (mm)	V (in)
INS14.06.88	88°	6	0.24
INS14.08.88	88°	8	0.31
INS14.10.88	88°	10	0.39
INS14.06.60	60°	6	0.24
INS14.08.60	60°	8	0.31
INS14.10.60	60°	10	0.39

Model	α	V (mm)	V (in)
INS14.06.45	45°	6	0.24
INS14.08.45	45°	8	0.31
INS14.10.45	45°	10	0.39
INS14.06.30	30°	6	0.24
INS14.08.30	30°	8	0.31

### TN80.20 1000 kN/m max.

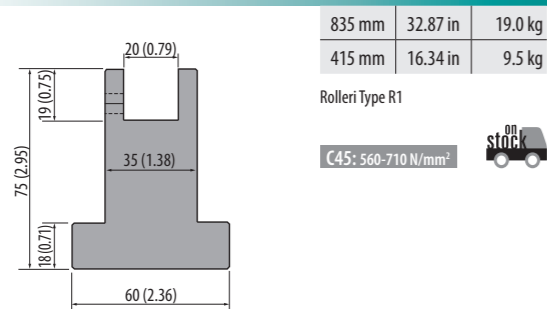

### INS20... 200 kN/m max.

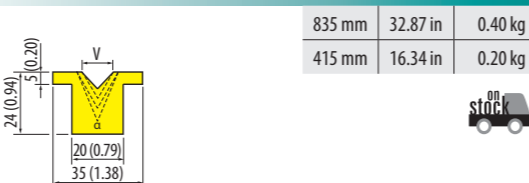

Model	α	V (mm)	V (in)
INS20.06.88	88°	6	0.24
INS20.08.88	88°	8	0.31
INS20.10.88	88°	10	0.39
INS20.12.88	88°	12	0.47
INS20.16.88	88°	16	0.63
INS20.06.60	60°	6	0.24
INS20.08.60	60°	8	0.31
INS20.10.60	60°	10	0.39
INS20.12.60	60°	12	0.47
INS20.16.60	60°	16	0.63

Model	α	V (mm)	V (in)
INS20.06.45	45°	6	0.24
INS20.08.45	45°	8	0.31
INS20.10.45	45°	10	0.39
INS20.12.45	45°	12	0.47
INS20.06.30	30°	6	0.24
INS20.08.30	30°	8	0.31
INS20.10.30	30°	10	0.39

# ROLLERI MARK FREE BENDING

## Synthetic Dies



### TN80.30 1000 kN/m max.

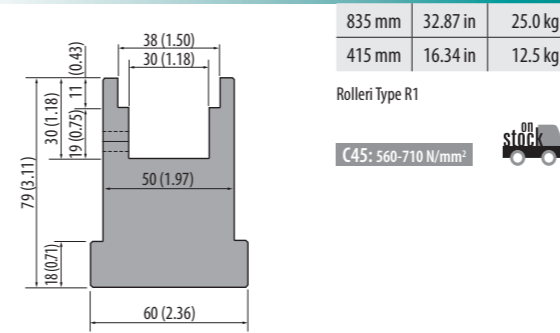

### INS30... 200 kN/m max.

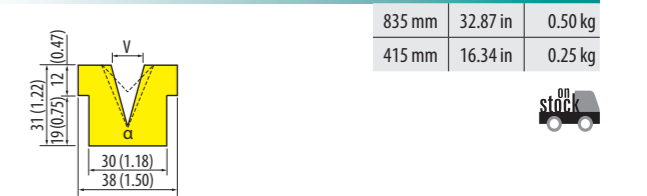

Model	α	V (mm)	V (in)
INS30.06.88	88°	6	0.24
INS30.08.88	88°	8	0.31
INS30.10.88	88°	10	0.39
INS30.12.88	88°	12	0.47
INS30.16.88	88°	16	0.63
INS30.20.88	88°	20	0.79
INS30.25.88	88°	25	0.99
INS30.06.60	60°	6	0.24
INS30.08.60	60°	8	0.31
INS30.10.60	60°	10	0.39
INS30.12.60	60°	12	0.47
INS30.16.60	60°	16	0.63
INS30.20.60	60°	20	0.79

Model	α	V (mm)	V (in)
INS30.06.45	45°	6	0.24
INS30.08.45	45°	8	0.31
INS30.10.45	45°	10	0.39
INS30.12.45	45°	12	0.47
INS30.16.45	45°	16	0.63
INS30.20.45	45°	20	0.79
INS30.06.30	30°	6	0.24
INS30.08.30	30°	8	0.31
INS30.10.30	30°	10	0.39
INS30.12.30	30°	12	0.47
INS30.16.30	30°	16	0.63

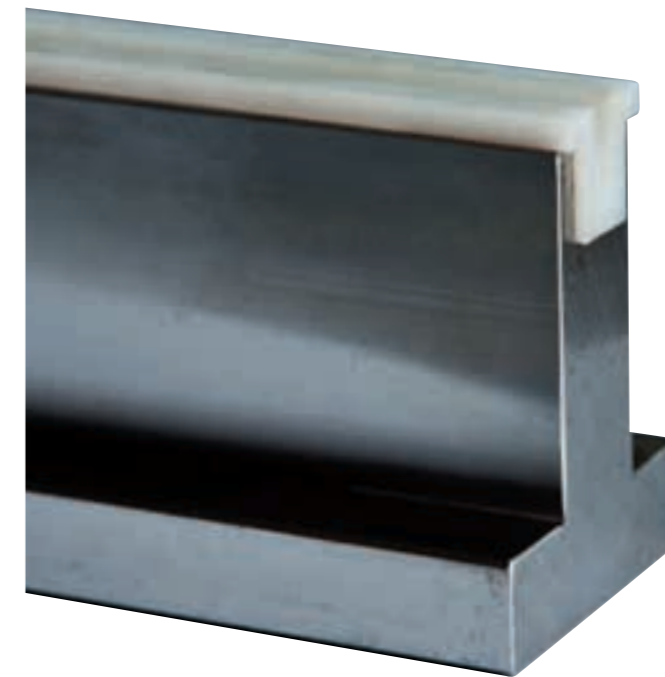

Articles on stock – Please note that delivery time varies according to your location.

## ROLLERI SPECIAL AND HEAVY DUTY TOOLS

Explanation of Special Tools	232
Explanation of Heavy Duty Tools	233
Heavy Duty Tools	234 - 235
Examples of Special Tools	236 - 238
Dies with Rollers	239 - 241
ROL6-System	242
Panelling Tools	242
BLACKFIRE	243





**Our Advantages – Your Convenience**

- in-house construction and production (no reseller or dealer)
- competent consulting
- client specific developments
- tracking of every tool possible, with a unique serial number on every article after the quality control check
- precision grinding (tolerance of +/-0.01mm)
- guaranteed tool reproduction
- exact parallelism
- bending tests upon request

**Special Tooling for:**

- Z-Profiles
- Hat-Profiles
- Trapezoidal Profiles
- Pressed contours
- Foldings
- Hinges
- Radii
- Beads
- Special Profiles
- etc.



**Material**

The raw material is obtained from qualified suppliers which compose the chemical formulas according to international standards. Therefore, guaranteeing high resilience and tensile strength.

Material Type	Mechanical resistance of the material and the tool body	Hardness of the material and the tool body	Hardness of the operating surfaces after induction hardening
42CrMo4	900-1150 N/mm <sup>2</sup>	29.1 - 36.9 HRC	54 - 60 HRC
C45	560-710 N/mm <sup>2</sup>	12 - 15.5 HRC	54 - 60 HRC
1.2767	830 N/mm <sup>2</sup>	22 - 25 HRC	54 - 60 HRC

- Specifications for the maximum press force kN/m are indicated as such, **1 t = 10 kN**.



**Our Advantages – Your Convenience**

The bending of materials with extreme high resistance, (Hardox, Weldom, etc.), has developed into an important task.

The Heavy Duty tools of Rollerli are built and finished for these challenges.

Tools that have a press force up to 4000 kN/m, offer you many production possibility.

Our many years of experience in the area of special and heavy duty tooling, along with our own developing department, guarantee you functional and economic solutions in the bending sector.

From the compatible tang to the punch onto the compatible die; we manufacture everything in our own production facilities.

Take advantage of the direct contact to the manufacturer and the benefits which come along with it.



Contact us now!  
We are here to help you!



RHD.300

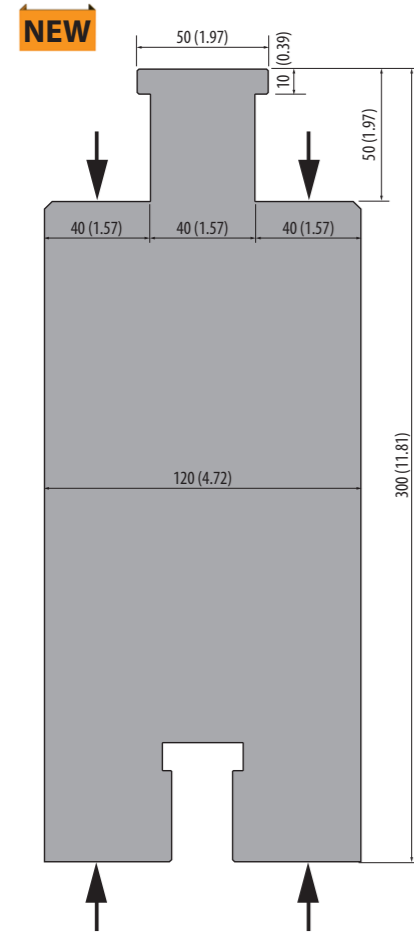

RHD.300-250		
500 mm	19.68 in	122.0 kg

2500 kN/m max.  
42Cr: 900-1150 N/mm<sup>2</sup>

RHD.300-400		
500 mm	19.68 in	122.0 kg

4000 kN/m max.  
1.2767: 830 N/mm<sup>2</sup>

RHD.300 HYD

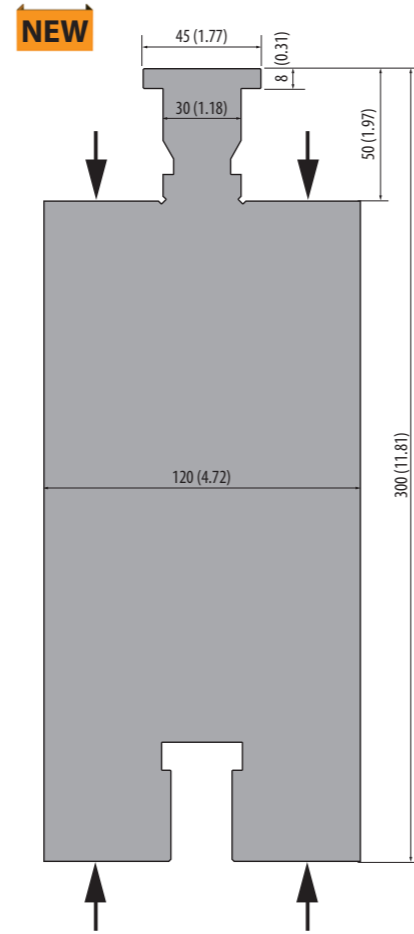

RHD.300-250 HYD		
500 mm	19.68 in	120.0 kg

2500 kN/m max.  
42Cr: 900-1150 N/mm<sup>2</sup>

RHD.300-400 HYD		
500 mm	19.68 in	120.0 kg

4000 kN/m max.  
1.2767: 830 N/mm<sup>2</sup>

RHDP.60

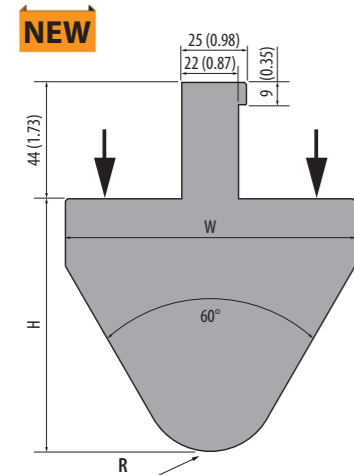

Model	2500 kN/m max.					
	H (mm)	H (in)	W (mm)	W (in)	R (mm)	R (in)
RHDP.60.20-250	96	3.78	110	4.33	20	0.79
RHDP.60.25-250	96	3.78	110	4.33	25	0.98
RHDP.60.30-250	96	3.78	110	4.33	30	1.18
RHDP.60.40-250	96	3.78	110	4.33	40	1.57
RHDP.60.50-250	96	3.78	110	4.33	50	1.97
RHDP.60.60-250	96	3.78	110	4.33	60	2.36
RHDP.60.70-250	86	3.39	140	5.51	70	2.76
RHDP.60.80-250	86	3.39	150	5.91	80	3.15
RHDP.60.90-250	86	3.39	165	6.50	90	3.54
RHDP.60.100-250	86	3.39	185	7.28	100	3.94

42Cr: 900-1150 N/mm<sup>2</sup>

Model	4000 kN/m max.					
	H (mm)	H (in)	W (mm)	W (in)	R (mm)	R (in)
RHDP.60.20-400	96	3.78	110	4.33	20	0.79
RHDP.60.25-400	96	3.78	110	4.33	25	0.98
RHDP.60.30-400	96	3.78	110	4.33	30	1.18
RHDP.60.40-400	96	3.78	110	4.33	40	1.57
RHDP.60.50-400	96	3.78	110	4.33	50	1.97
RHDP.60.60-400	96	3.78	110	4.33	60	2.36
RHDP.60.70-400	86	3.39	140	5.51	70	2.76
RHDP.60.80-400	86	3.39	150	5.91	80	3.15
RHDP.60.90-400	86	3.39	165	6.50	90	3.54
RHDP.60.100-400	86	3.39	185	7.28	100	3.94

1.2767: 830 N/mm<sup>2</sup>

500 mm | 19.68 in

RHD.500-200

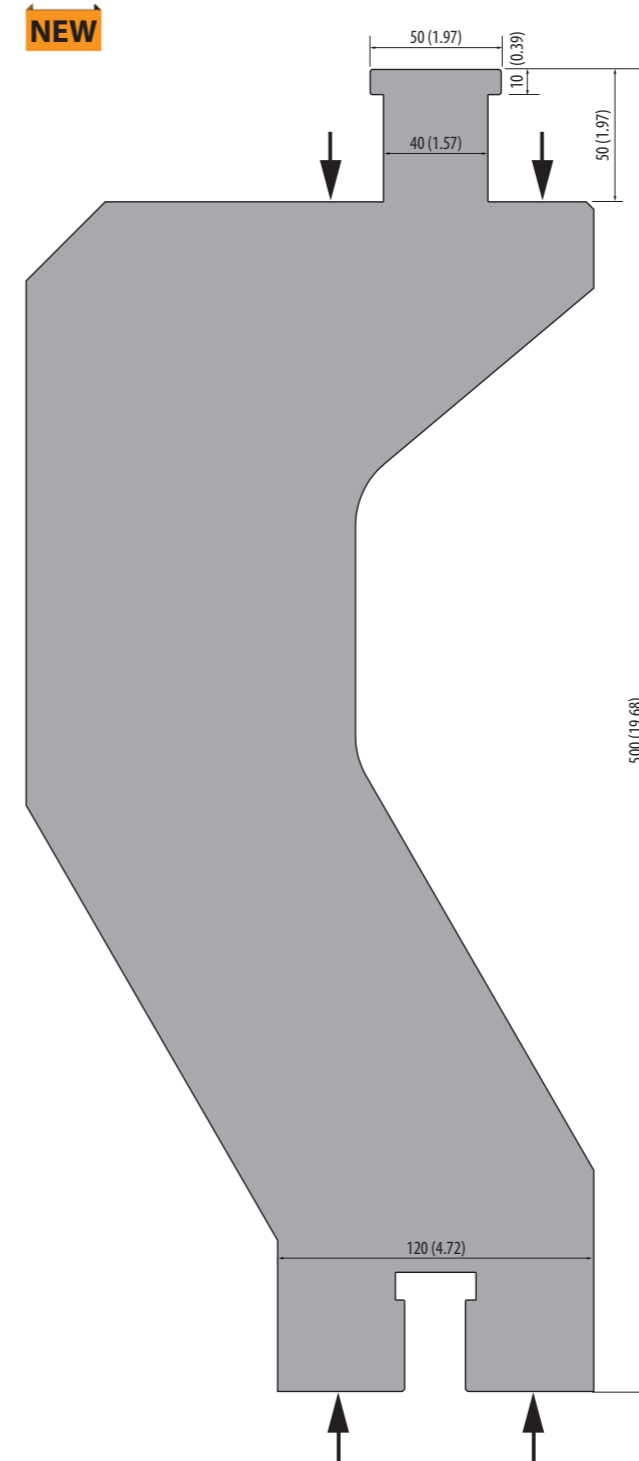

2000 kN/m max.  
150 mm | 19.68 in | 253.0 kg

42Cr: 900-1150 N/mm<sup>2</sup>

More Tools for Heavy Duty operations can be found on pages 156-158



Tool examples

SPE1 Hat-Profiles

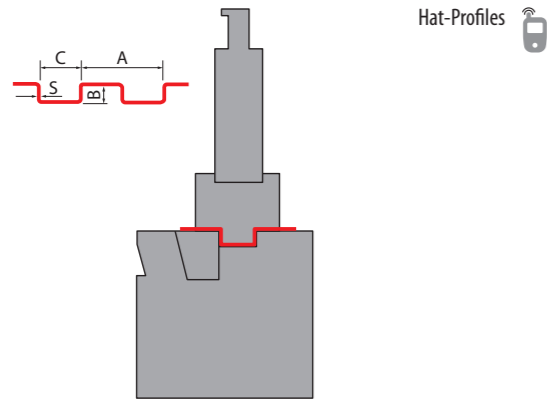

SPE2 Z-Profiles

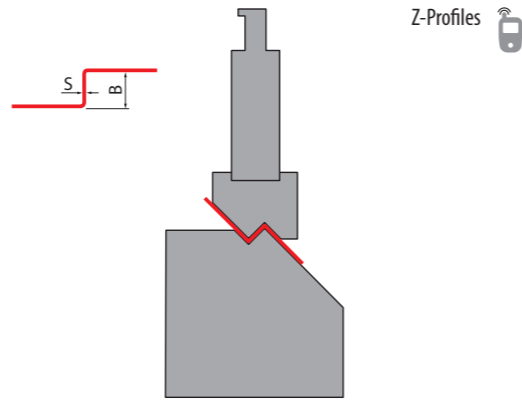

SPE3 Trapezoidal Profiles

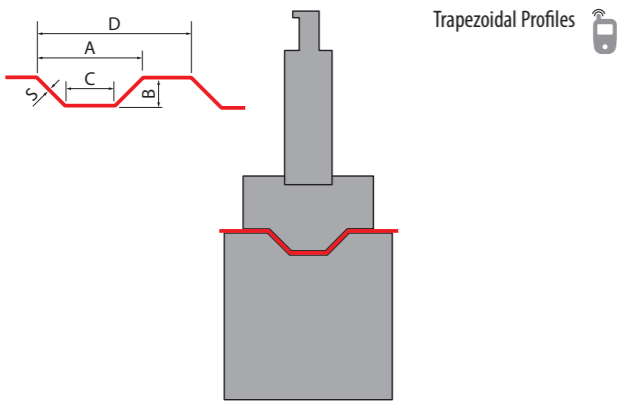

SPE4 Trapezoidal Profiles

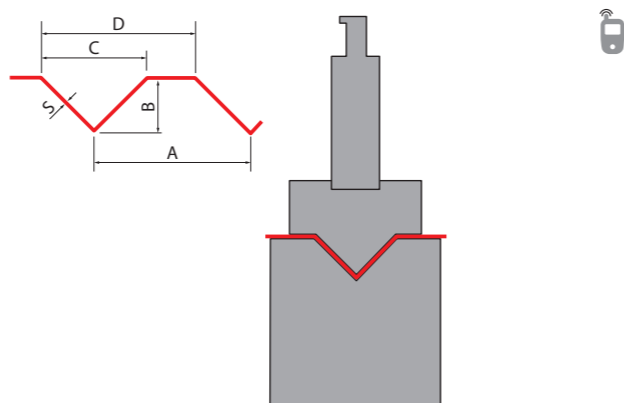

SPE5 Hinges

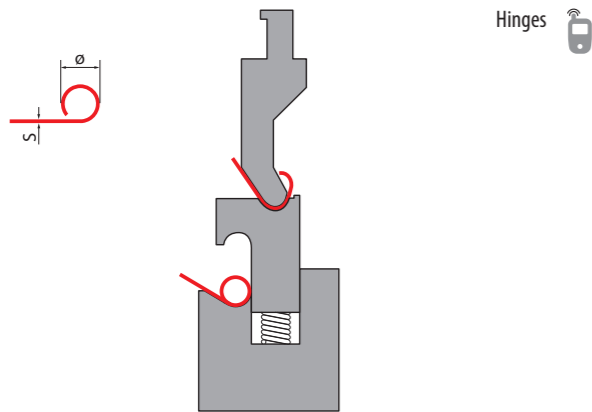

SPE6 Hinges

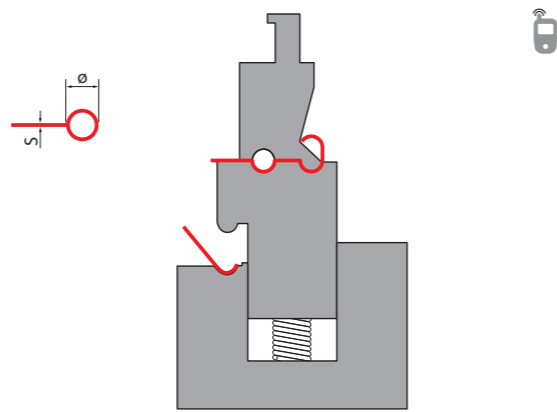

SPE7

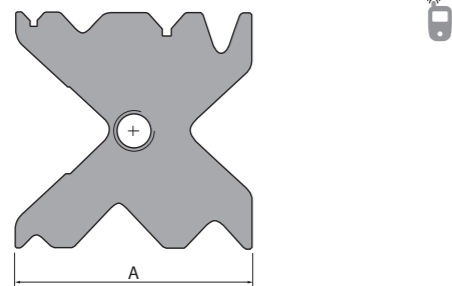

SPE-X

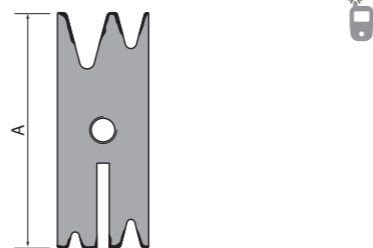

SPE9

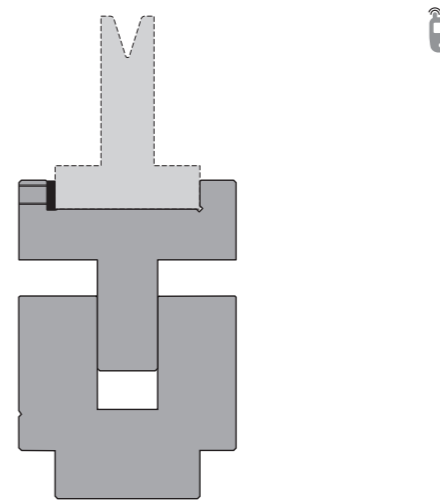

SPE-P1

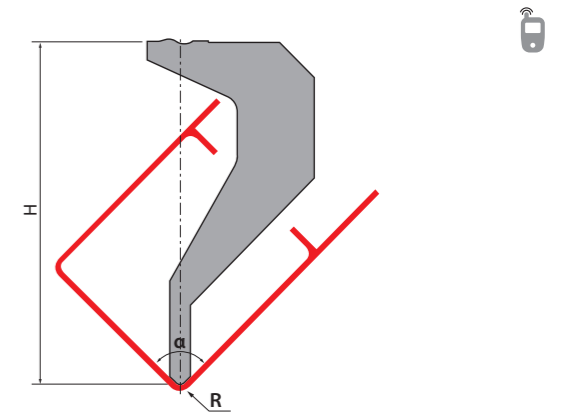

SPE-P2

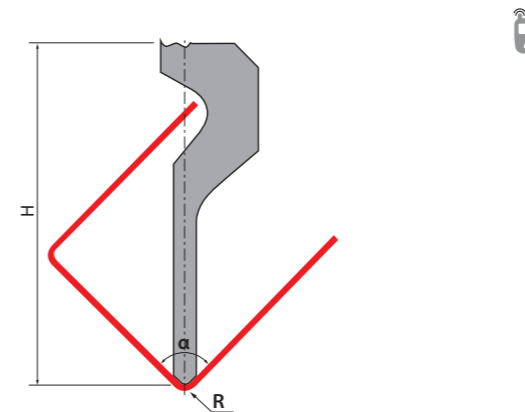

SPE-P3

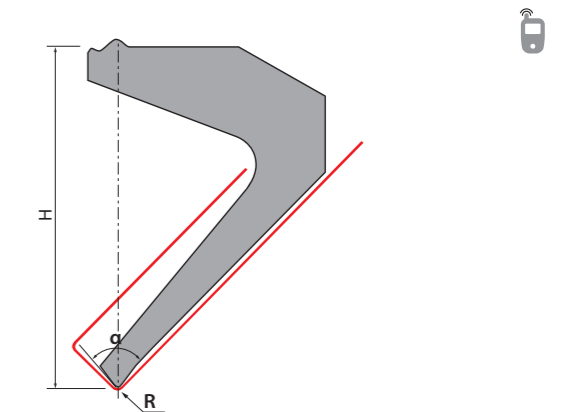

SPE-P4

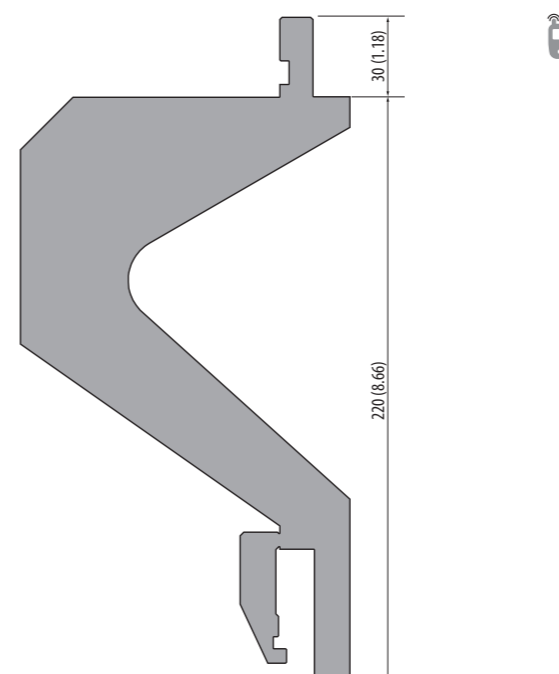

Front- and Hemming Tool (Foldings)

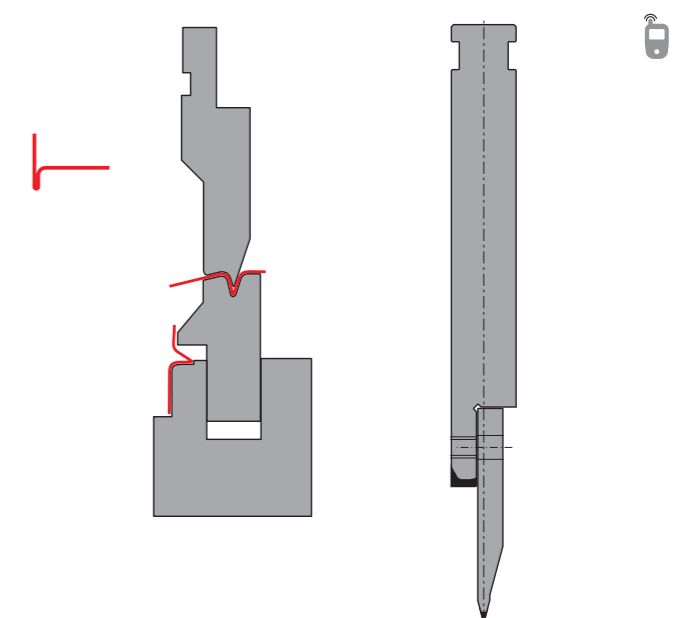

Tool examples

Radii Pressing

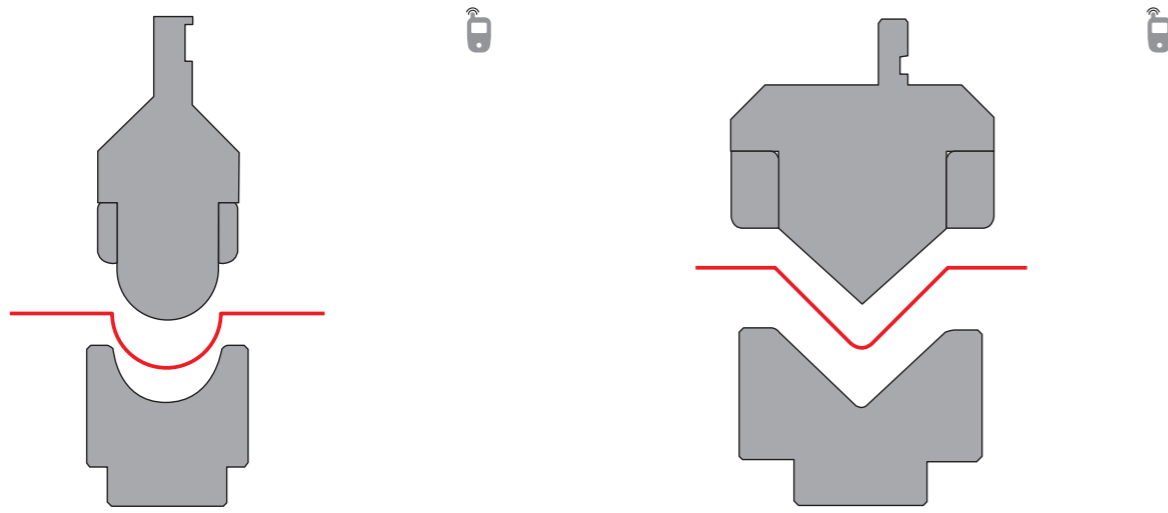

Special Profiles

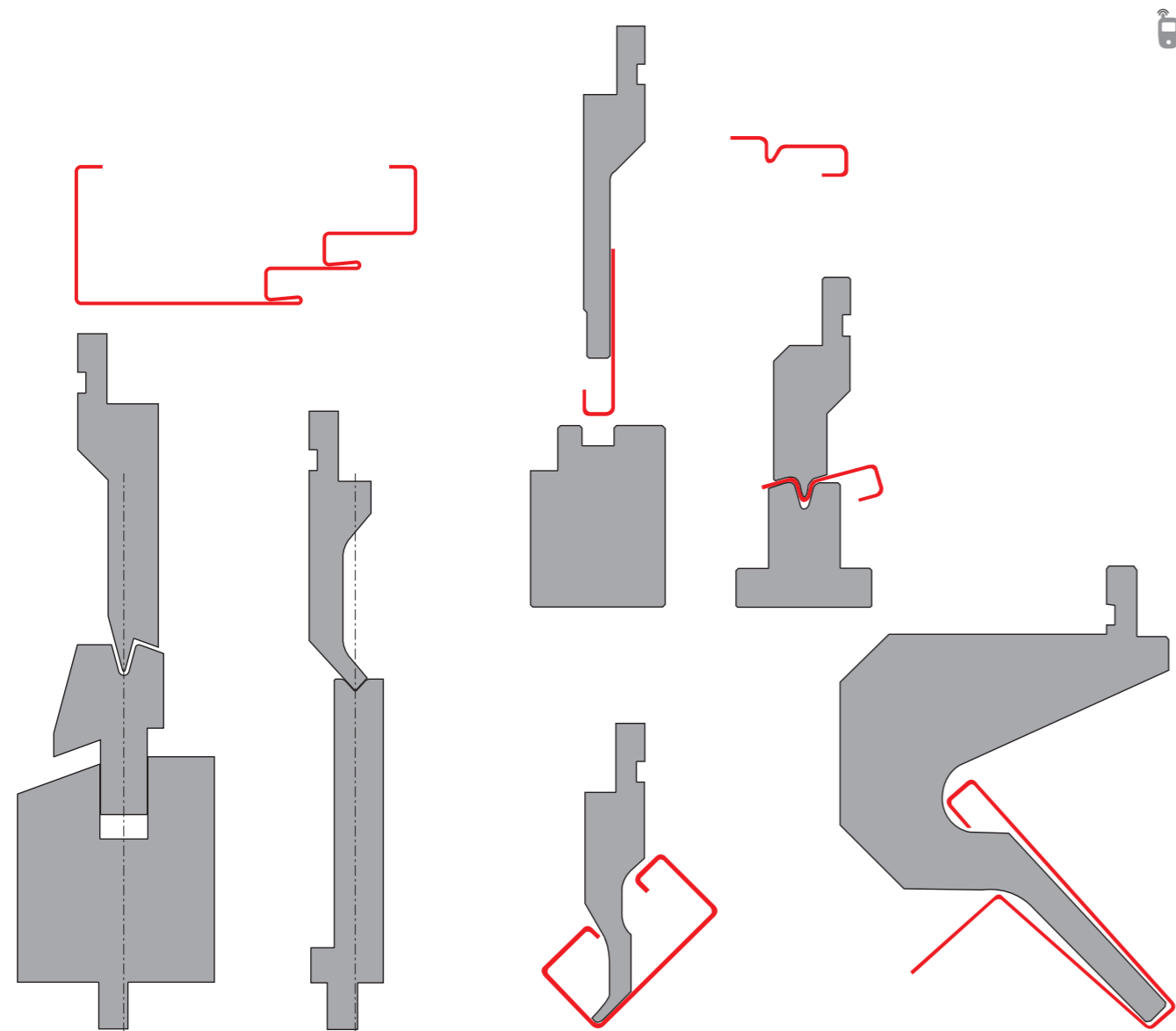

Dies with Rollers

MR90

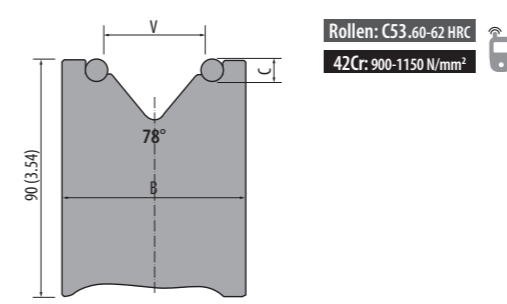

MR130

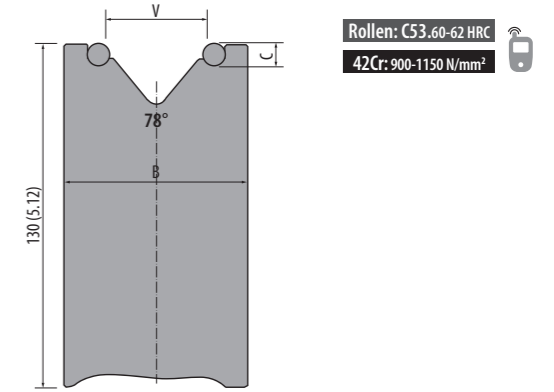

Model	V (mm)	V (in)	B (mm)	B (in)	C (mm)	C (in)	Length (mm)	Length (in)	Weight (kg)
MR90.20.78	20	0.79	45	1.77	6	0.24	835	32.87	15.0
MR90.24.78	24	0.94	49	1.93	6	0.24	835	32.87	17.0
MR90.30.78	30	1.18	60	2.36	8	0.31	835	32.87	21.0
MR90.40.78	40	1.57	70	2.76	8	0.31	835	32.87	24.0
MR90.50.78	50	1.97	84	3.31	10	0.39	835	32.87	28.0
MR90.60.78	60	2.36	94	3.70	10	0.39	835	32.87	31.0
MR90.70.78	70	2.76	104	4.09	10	0.39	835	32.87	35.0

Model	V (mm)	V (in)	B (mm)	B (in)	C (mm)	C (in)	Length (mm)	Length (in)	Weight (kg)
MR130.20.78	20	0.79	45	1.77	6	0.24	835	32.87	22.0
MR130.24.78	24	0.94	49	1.93	6	0.24	835	32.87	25.0
MR130.30.78	30	1.18	60	2.36	8	0.31	835	32.87	28.0
MR130.40.78	40	1.57	70	2.76	8	0.31	835	32.87	34.0
MR130.50.78	50	1.97	84	3.31	10	0.39	835	32.87	40.0
MR130.60.78	60	2.36	94	3.70	10	0.39	835	32.87	45.0
MR130.75.78	75	2.95	118	4.65	16	0.63	835	32.87	50.0
MR130.80.78	80	3.15	123	4.84	16	0.63	835	32.87	55.0
MR130.90.78	90	3.54	133	5.24	16	0.63	835	32.87	60.0
MR130.100.78	100	3.94	143	5.63	16	0.63	835	32.87	65.0
MR130.120.78	120	4.72	163	6.42	16	0.63	835	32.87	70.0

A10

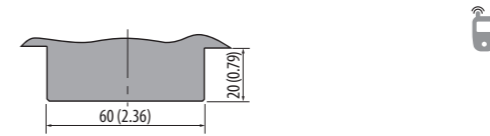

A11

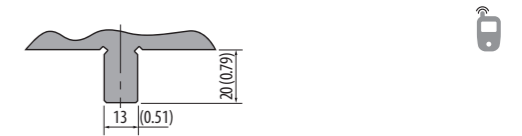

A13

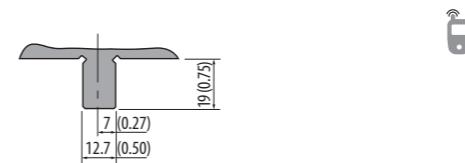

Our Advantages – Your Convenience

- increase in wear resistance through rollers
- induction hardened rollers (approx. 60 HRC)
- decrease in bending marks
- decrease in press force
- easy and economic exchange of rollers

AD MR13

NEW



98 mm 3.86 in  
Adapter for Rolleri Type R2/R3  
C45: 560-710 N/mm<sup>2</sup>

AD MR55

NEW

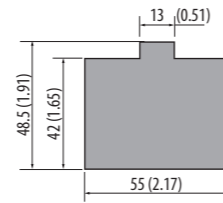

98 mm 3.86 in  
Adapter for Rolleri Type RX EHT  
C45: 560-710 N/mm<sup>2</sup>

AD MR35

NEW

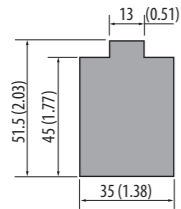

98 mm 3.86 in  
Adapter for Rolleri Type RX Weinbrenner  
C45: 560-710 N/mm<sup>2</sup>

AD MR12.7

NEW

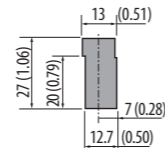

98 mm 3.86 in  
Adapter for Rolleri Type RX LVD  
C45: 560-710 N/mm<sup>2</sup>

MR170.200.80

NEW

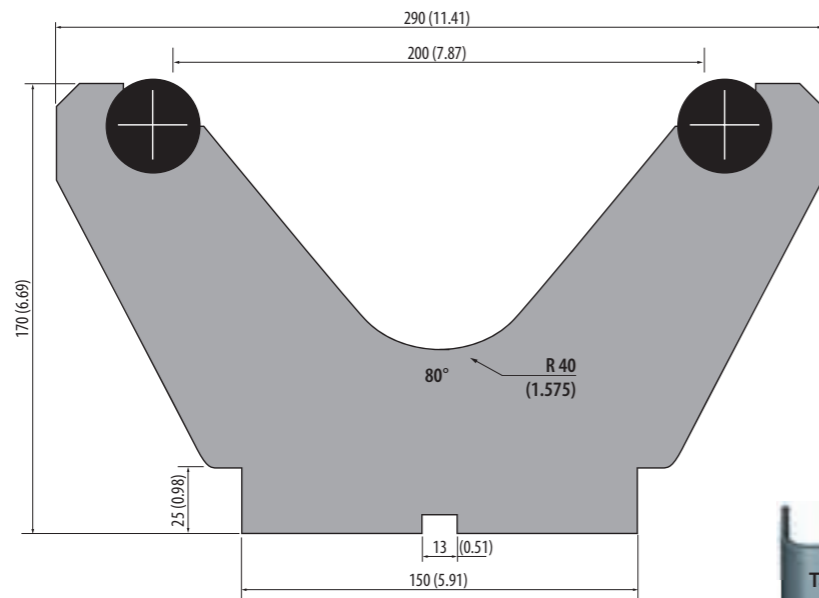

2000 kN/m max.  
100 mm 3.94 in 19.0 kg  
42Cr: 900-1150 N/mm<sup>2</sup>

Take advantage of our dies with rollers with means of groove bars/tails to use on other press brake machines.

MR200.250.80

NEW

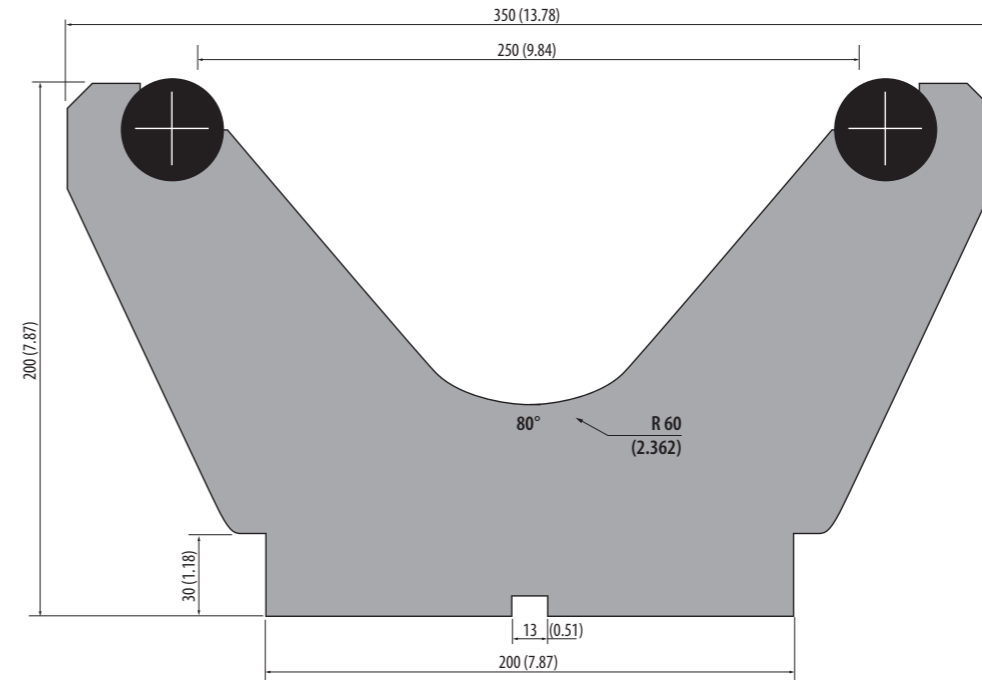

2000 kN/m max.  
100 mm 3.94 in 28.0 kg  
42Cr: 900-1150 N/mm<sup>2</sup>

MR250.320.80

NEW

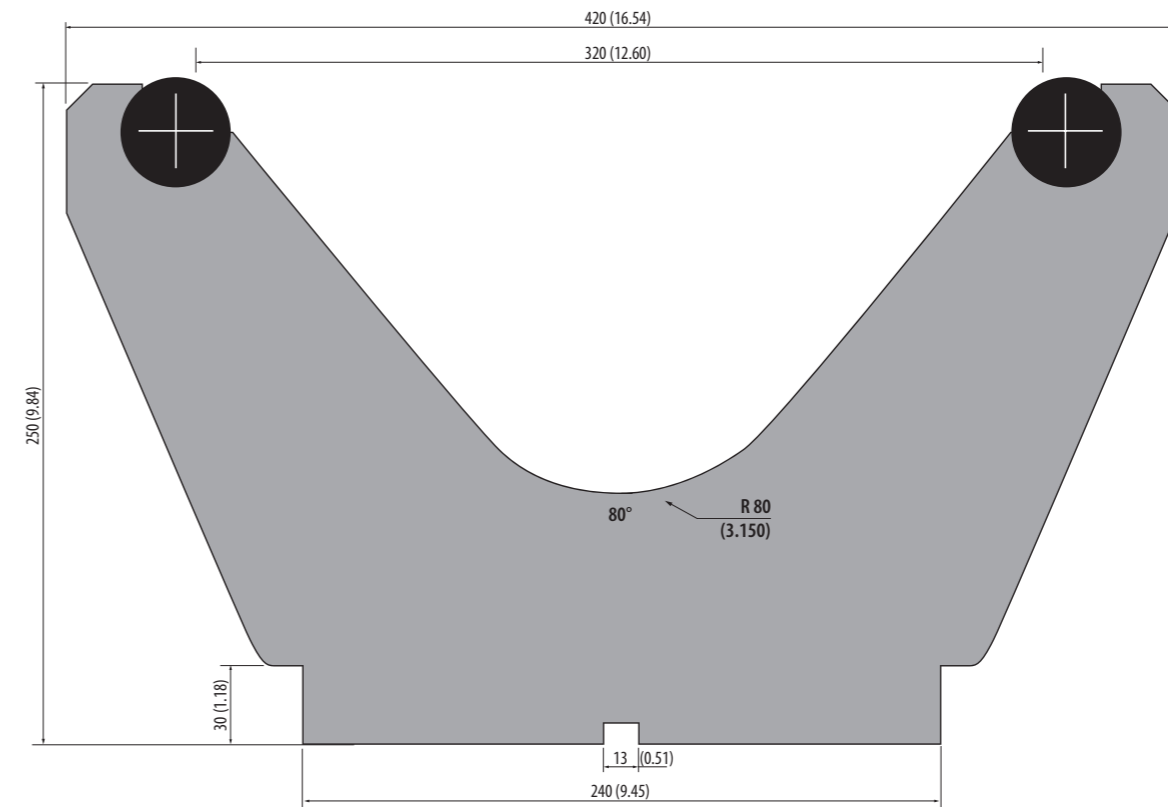

2000 kN/m max.  
100 mm 3.94 in 42.0 kg  
42Cr: 900-1150 N/mm<sup>2</sup>

ROL6-System

Our Advantages – Your Convenience

- various V-Openings: 40-360 mm (1.57-14.17 in)
- Instructions:
  - secured manually with steering wheel
  - driven by gear motor or
  - CNC-system

While using the manual version, the opening is set in place by a turn of the steering wheel, or with a gear reduction which is attached to the die.

The automatic version, on the other hand, is operated by a control panel. The standard system does not come with the CNC-Connection for the press brake. It is available upon request at an additional cost.

The base of the ROL6-system is 720 mm (28.35 in) wide, but can also be fitted onto narrow designed tables. There is a adapter available in order to secure the system onto a table with a width of 400 mm (15.75 in). The inserts in the opening radius are exchangeable. The standard version comes with an opening radius of R=10 mm (0.39 in).

Die weight: approx. 1 ton/m

ROL6

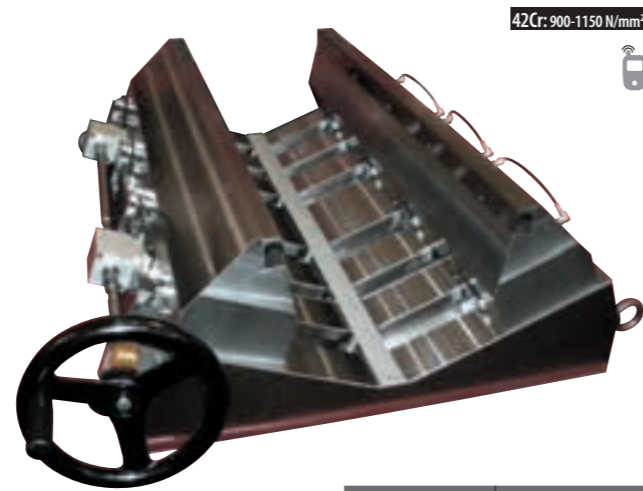

42Cr: 900-1150 N/mm<sup>2</sup>

bending angle	kN/m max.
0°	6000
90°	6000
60°	4000

 **Rolleri Videos**  
 Application of various dies ROL6:  
[www.rolleritools.com/videos/rol6](http://www.rolleritools.com/videos/rol6)

Panelling Tools

Our Advantages – Your Convenience

- in-house construction (no reseller or dealer)
- production according to your specifications
- tracking of every tool possible, with a unique serial number on every article after the quality control check.
- precision grinding (tolerance of +/-0.01 mm)
- exact parallelism
- use of the best materials, guaranteed high resistance and tensile strength

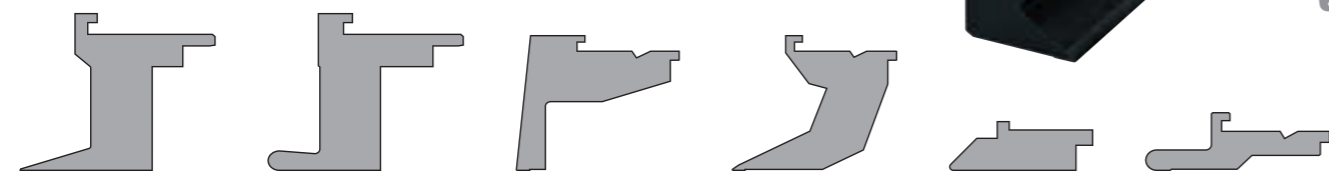

BLACKFIRE



The Unique Coating

Rolleri BLACKFIRE is a particular coating of your tools which defines itself by its increased corrosion resistance and special design.

The chemical treatment permanently solves the problem of oxidation.

The top surface of the metals changes through the phosphate process. It builds phosphate-like crystals, that attach themselves chemically on the substance. This improves the durability of the surface against corrosion.

Your equipment will have a long-term lifecycle left unchanged. The glossy black color of BLACKFIRE is compatible with the new technology and that allows a unique and esthetic look which connects well with the advantages of it.

You can have the BLACKFIRE treatment on all standard tools with a surcharge of 30%.

Please note that the delivery times vary by a BLACKFIRE Treatment.

Our Advantages – Your Convenience

- no corrosion
- better gliding by the exchange of tools
- appealing design
- long-life cycle



## ROLLERI SERVICES / MODIFICATIONS

Our Production Department	246 - 247
Modified Tangs	248 - 249
Special Sectioning	250
Horn Pieces	250
Modifying the V-Opening	250
Radius and Angle Modification	251
Grooves for Dies	251
Grooves and Groove Bars/Tails for Dies	252
Gaps and Windows	253

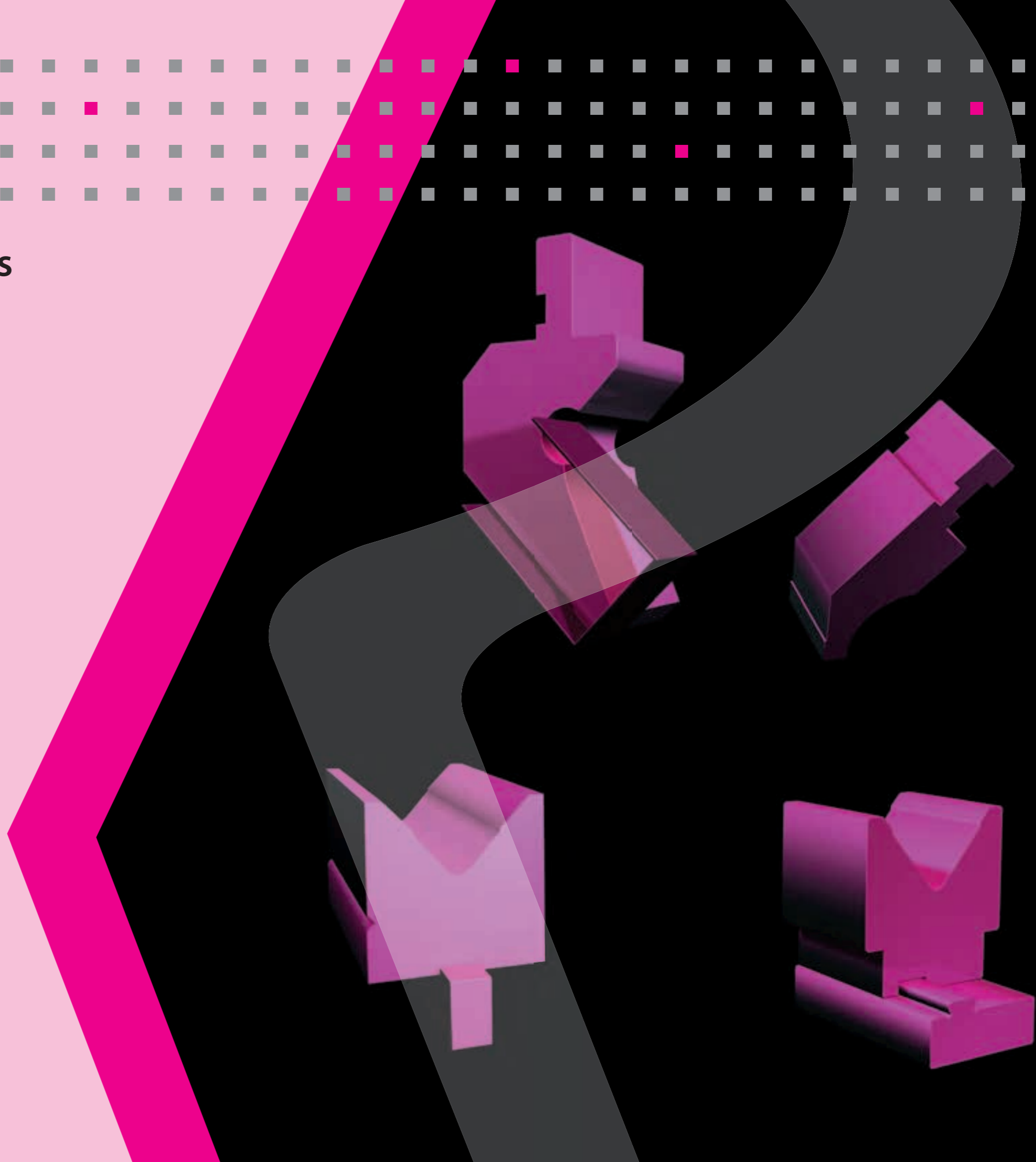

**Our Machine Park**

Our comprehensive machinery with state-of-the-art technology ensures you the highest quality in tools.

In addition to the manufactured standard and special tools, we perform all modifications individually according to your requirements.

Take advantage the modifications to reduce costs and increase the productivity of your existing tools!

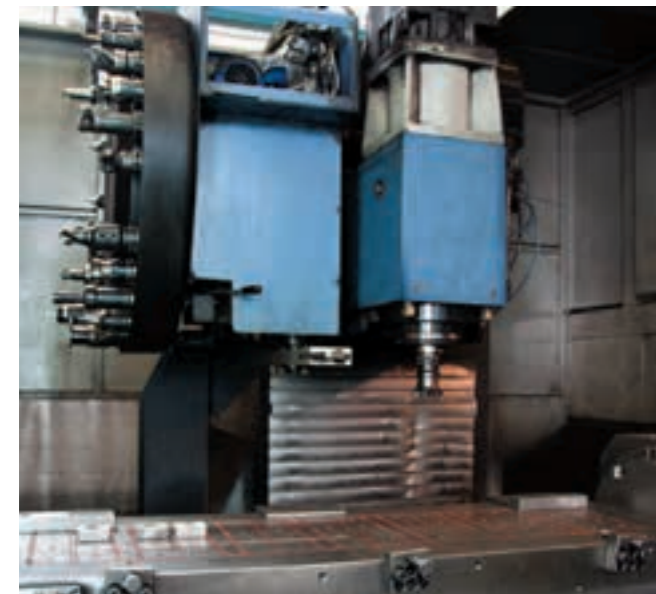

**CNC-Milling**

With our state-of-the-art milling centers we can do your modification requests fast, precise and with high-quality.

Swivel milling heads with high swivel range allows flexible and universal production.

This is where, grooves, gaps, and openings are created.

**CNC-Profile Grinding**

Our CNC-Professional grinding machines guarantee, highest precision ground (tolerance of +/-0.01 mm), accurate parallelism and repeatability.

Here you can also retrofit induction hardened and core hardened tool pieces. Radius and angle modifications are percisely grounded after your measurements.



**Hardening**

The surface areas of the tools are exposed to the highest mechanical stress. Due to the fact that, the whole press force of the press brake machine is focused on small surface of the sheet metal. Therefore the stress is very high on these surfaces. During the bending process of the sheet metal, friction occurs.

For more resistance strength the hardening of the surfaces can be increased. The depth of the hardening must be at least 3 mm to avoid deformations. We use the electromagnetic technique also known as induction hardening to the best quality for your money's worth.

**Quality Control and Laser Marking**

After the laser marking, tracking of every tool is possible with a unique serial number on every article. Therefore the tracking of your tools is guaranteed and a new productions with the exact same meausrements (angle, radius, hardening, etc.) is possible. This step is happens after quality control.

Individual markings are upon request possible.

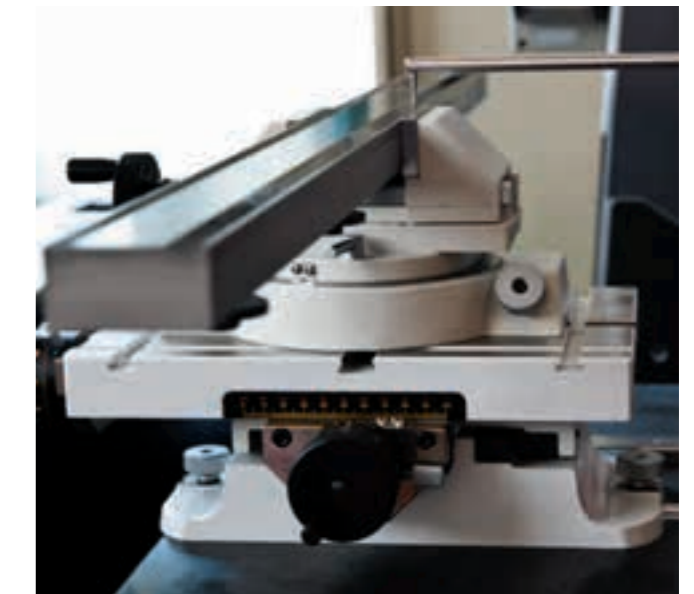

**EDM Wire**

By using EDM wire, hardened and very tough material can be retrofitted. The process is operated based on a CAD-system which can also process high dimensions such as special shapes.



## ROLLERI MODIFICATIONS

... for standard tangs

### Modified Tangs

- Rolleri Punches Type R1, R2, and R3 can be used on other press brake machines by modifying the tang.
- Precision ground (Tolerance of +/-0.01 mm)
- exact parallelism
- fast, economic, percise

### Standard Rolleri Type R1

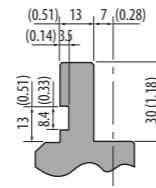

Fast delivery on these items guaranteed. Please note that delivery terms vary according to your location.

### OT

- Modification for:
- for Amada fast clamping system

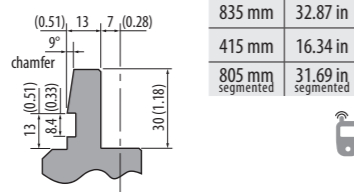

835 mm	32.87 in
415 mm	16.34 in
805 mm segmented	31.69 in segmented

### A1

- Groove in addition to 8.4 x 3.5 mm (0.33 x 0.14 in) groove for:
- pneumatic clamping system

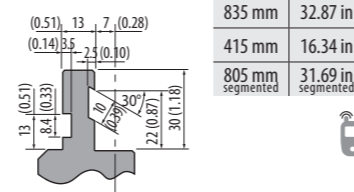

835 mm	32.87 in
415 mm	16.34 in
805 mm segmented	31.69 in segmented

### A6

- Groove in addition to 8.4 x 3.5 mm (0.33 x 0.14 in) groove for:
- Rolleri Type R3
  - Bystronic-Beyeler Euro
  - Safan

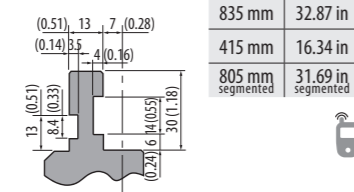

835 mm	32.87 in
415 mm	16.34 in
805 mm segmented	31.69 in segmented

### A7

- Groove in addition to 8.4 x 3.5 mm (0.33 x 0.14 in) groove and shortened tang for:
- Rolleri Type R3
  - Bystronic-Beyeler Euro
  - Safan

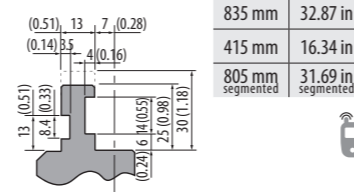

835 mm	32.87 in
415 mm	16.34 in
805 mm segmented	31.69 in segmented

### A8

- Groove Bar/Tail for:
- hydraulic clamping system Gasparini

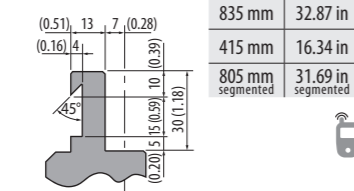

835 mm	32.87 in
415 mm	16.34 in
805 mm segmented	31.69 in segmented

### A41

- older clamping system

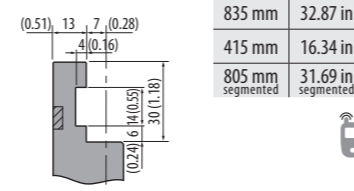

835 mm	32.87 in
415 mm	16.34 in
805 mm segmented	31.69 in segmented

### A42

- older clamping system

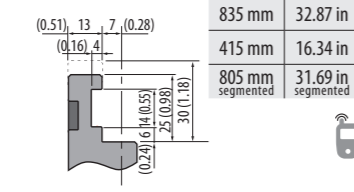

835 mm	32.87 in
415 mm	16.34 in
805 mm segmented	31.69 in segmented

### A43

- Groove with steel bar for:
- segmented punches

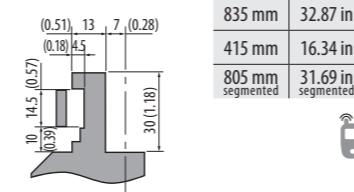

835 mm	32.87 in
415 mm	16.34 in
805 mm segmented	31.69 in segmented

## ROLLERI MODIFICATIONS

... for standard tangs



### Standard Rolleri Type R2

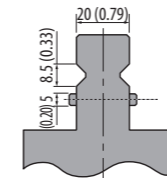

### Modification examples Type R2

production according to your specifications

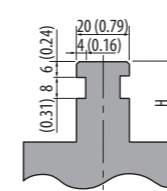

production according to your specifications

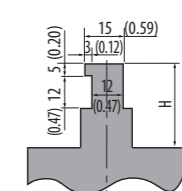

Take advantage of your existing tools with means of modifications.

### Standard Rolleri Type R3

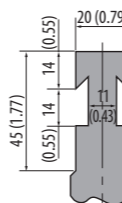

### Modification examples Type R3

production according to your specifications

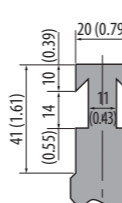

production according to your specifications

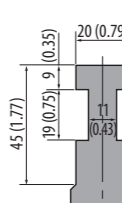

## ROLLERI MODIFICATIONS

### Special Sectioning

- Individual sectioning of your punches and dies
- fast, economic, precise

Pro separation cutting causes a decrease in length of approx. 5 mm

#### Special Sectioning of Punches

Example of punches production according to your specifications

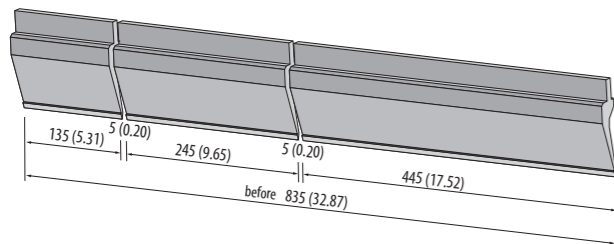

#### Special Sectioning of Dies

Example of Dies production according to your specifications

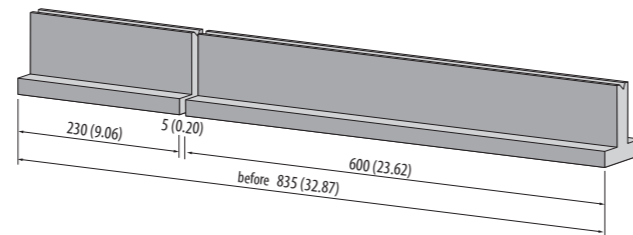

## Horn Pieces

- individual horn pieces on punches and dies
- on one or both sides
- fast, economic, precise

#### Horn Pieces for Punches

Punch example production according to your specifications

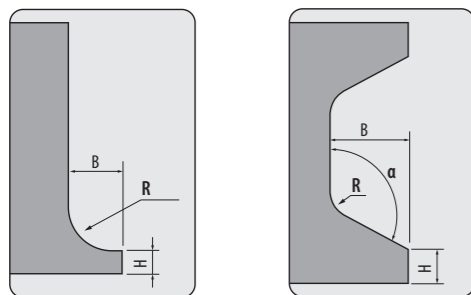

#### Horn Pieces for Dies

Die example production according to your specifications

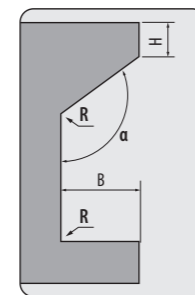

## Modifying the V-Opening

- individual modification for dies
- fast, economic, precise

#### Modifying the V-Opening

Example production according to your specifications

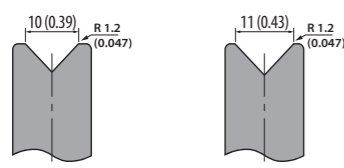

Give us a call for more information!

## ROLLERI MODIFICATIONS

### Radius and Angle Modifications

- Individual modifications of your punches and dies
- fast, economic, precise

#### Radius Modifications for Punches

Radii modification Punch example production according to your specifications

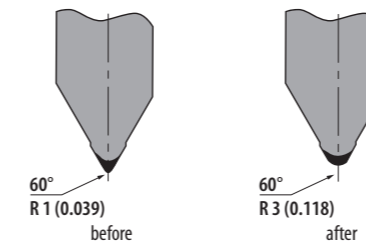

#### Radius Modifications for Dies

Opening Radius modification die example production according to your specifications

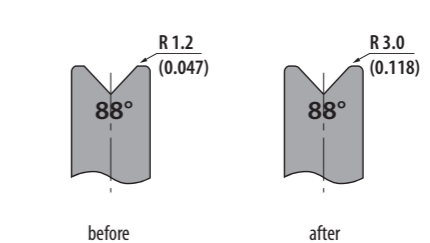

#### Angle Modification Punches

Angle modification punch example production according to your specifications

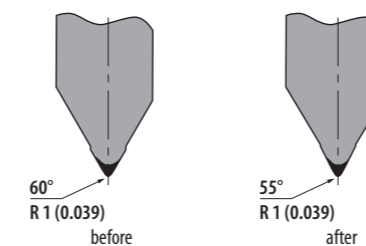

#### Angle Modification Dies

Angle modification die example production according to your specifications

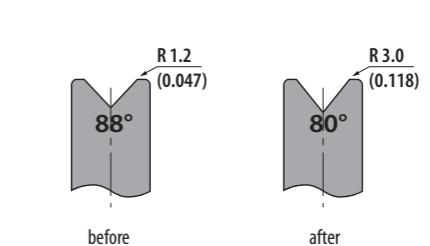

## Grooves for Dies

- Milling of grooves for use on other press brake systems
- fast, economic, precise

#### Mounting example

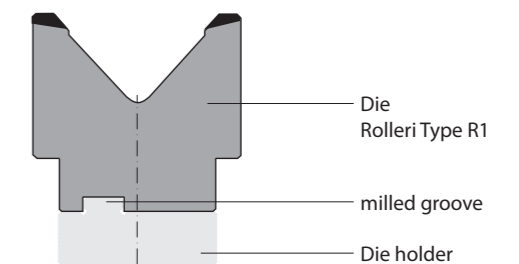

Delivery within 3 business days. Upon concordance even faster!

#### A28

Groove for die holder

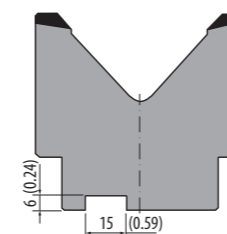

835 mm	32.87 in
415 mm	16.34 in
805 mm segmented	31.69 in segmented

#### A29

groove production according to your specifications

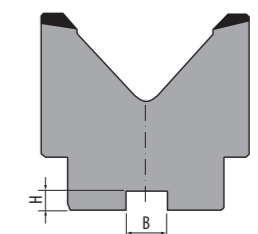

835 mm	32.87 in
415 mm	16.34 in
805 mm segmented	31.69 in segmented

## ROLLERI MODIFICATIONS

### Grooves und Groove Bars/Tails for Dies

- For milling of the groove and the insert of a ground groove bar/tail the exact measurement is needed to use on other press brake systems
- fast, economic, percise

#### Mounting example

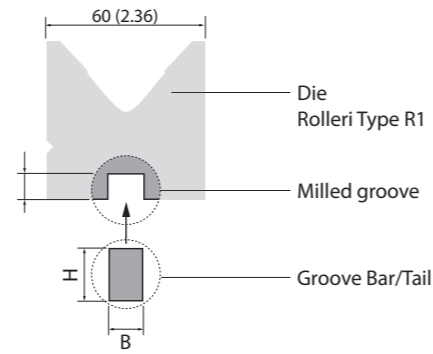

#### A30

Groove Bars/Tails:  
13 x 30 mm (0.51 x 1.18 in) for  
• Roller Type R2  
• Roller Type R3

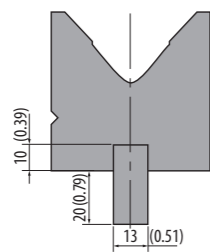

835 mm	32.87 in
415 mm	16.34 in
805 mm segmented	31.69 in segmented

#### A31

Groove Bars/Tails:  
12 x 29 mm (0.47 x 1.14 in) for  
• Roller Type RX LVD

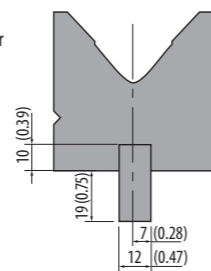

835 mm	32.87 in
415 mm	16.34 in
805 mm segmented	31.69 in segmented

#### A32

Groove Bars/Tails:  
12.7 x 29 mm (0.50 x 1.14 in) for  
• Roller Type RX LVD

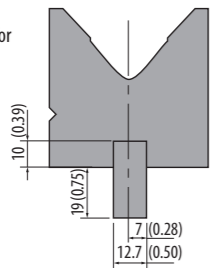

835 mm	32.87 in
415 mm	16.34 in
805 mm segmented	31.69 in segmented

#### A44

Groove Bars/Tails:  
55 x 55 mm (2.17 x 2.17 in) for  
• Roller Type RX EHT

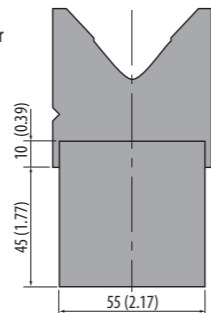

835 mm	32.87 in
415 mm	16.34 in
805 mm segmented	31.69 in segmented

#### A45

Groove Bars/Tails:  
35 x 55 mm (1.38 x 2.17 in) for  
• Roller Type RX Weinbrenner

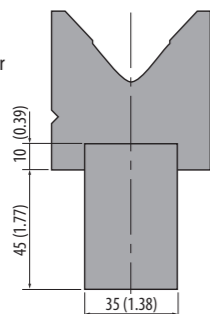

835 mm	32.87 in
415 mm	16.34 in
805 mm segmented	31.69 in segmented

#### AX

individual Groove Bars/Tails  
for other systems

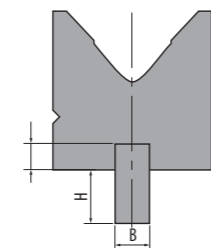

835 mm	32.87 in
415 mm	16.34 in
805 mm segmented	31.69 in segmented

## ROLLERI MODIFICATIONS

### Gaps and Windows

- The retrofitting of the tool edges of long parts, short U-profiles and similar
- fast, economic, percise

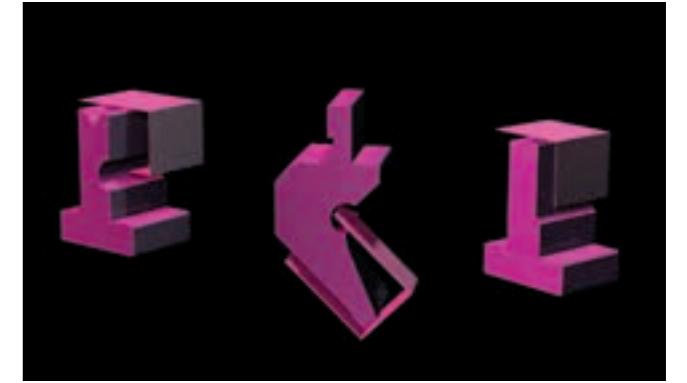

#### Gaps on Punches

Example Punches  
production according to your specifications

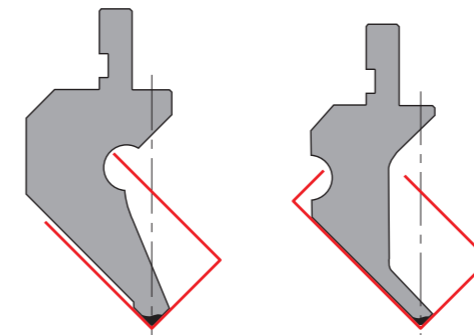

#### Gaps on Dies

Example Dies  
production according to your specifications

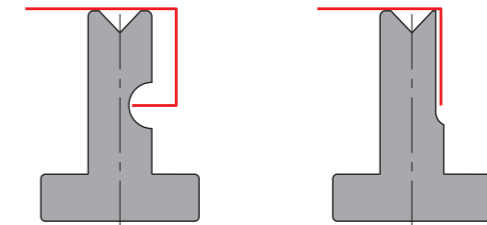

#### Windows for Punches

Example Punches  
production according to your specifications

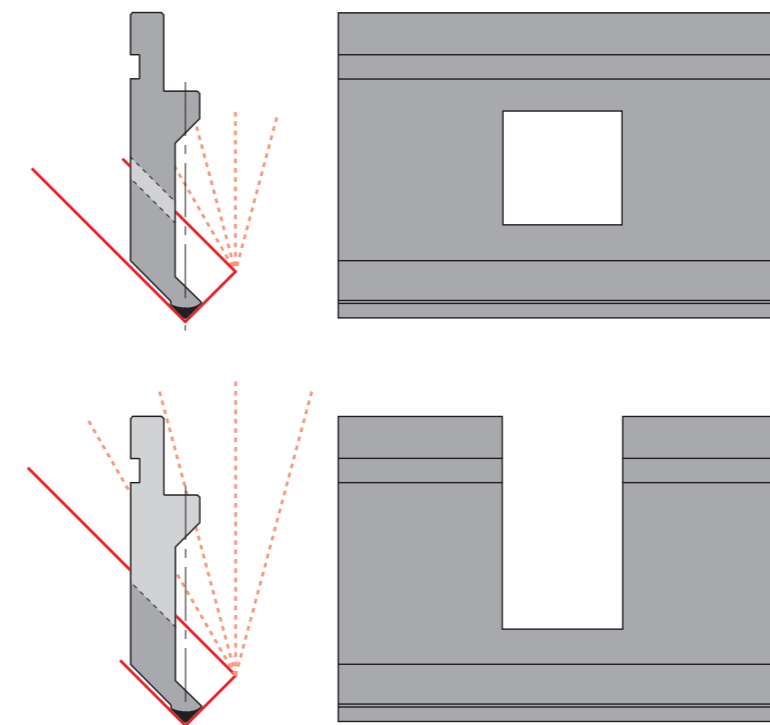

For Roller BLACKFIRE  
see page 243

## ROLLERI SHEAR BLADES AND ACCESSORIES

Tooling Cabinets	256 - 257
Tool Trolley	258
Bending Box	258
Squaring Arms	259
Supporting Arms	260
Back Gauge	260
Shear Blades	260 - 261

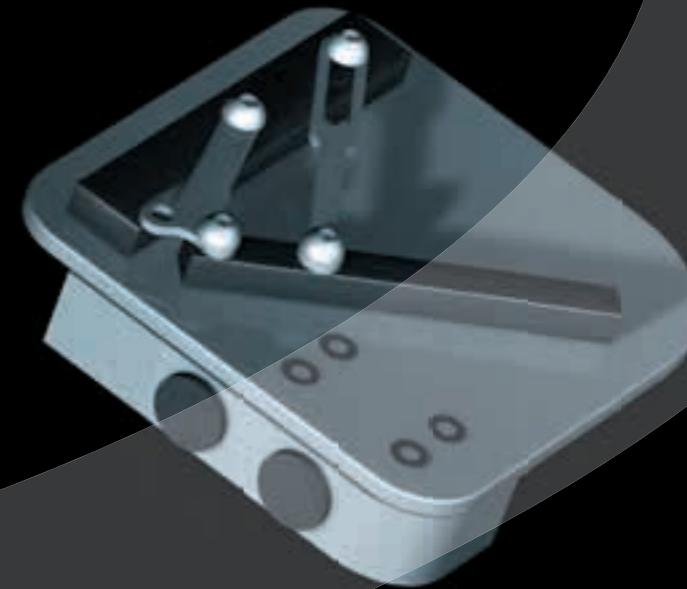

## ROLLERI ACCESSORIES

### Tooling Cabinets

#### Our Advantages – Your Convenience

- Protection against contamination and damage
- Faster access
- Robust construction
- Clear and tidy storage
- Cabinet doors specially designed for lift trucks and truck
- Adjustable height, zinc-plated shelves



#### Rolleri Videos

Tool storage demonstration at:  
[www.rolleritools.com/videos/tooling-cabinets](http://www.rolleritools.com/videos/tooling-cabinets)



#### ARM 835-4 for max. tool length = 835 mm (32.87 in)



850 x 1240 x 1050 (W x H x D)  
 33.46 x 48.82 x 41.34 (W x H x D)

for Tools Roller Type R1  
 approx. 20 m (787.40 in)  
 Storage capacity



Equipment	
4 Drawers	vertical, on wheels (see CS-1)
16 Shelves	for type R1 with 13 mm (0.51 in) tangs (see shelves UC-13-1)
4 Shelves	for type R1 with 13 mm (0.51 in) tangs (see shelves UL-13-3)
Weight	271.0 kg

#### ARM 835-5 for max. tool length = 835 mm (32.87 in)



1040 x 1240 x 1050 (W x H x D)  
 40.94 x 48.82 x 41.34 (W x H x D)

for Tools Roller Type R1  
 approx. 25 m (984.25 in)  
 Storage capacity



Equipment	
5 Drawers	vertical, on wheels (see CS-1)
20 Shelves	for type R1 with 13 mm (0.51 in) tangs (see shelves UC-13-1)
5 Shelves	for type R1 with 13 mm (0.51 in) tangs (see shelves UL-13-3)
Weight	350.0 kg

#### ARM 1060-4 / -CV for max. tool length = 1060 mm (41.73 in)



850 x 1240 x 1360 (W x H x D)  
 33.46 x 48.82 x 53.54 (W x H x D)

for Tools Roller Type R2/R3  
 approx. 26 m / 39 m (1023.62 in /  
 1535.43 in) Storage capacity



Equipment ARM 1060-4	
4 Drawers	vertical, on wheels (see CS-2)
16 Shelves	for type R2/R3 with 20 mm (0.79 in) tangs (see shelves UC-20-2)
4 Shelves	for type R2/R3 with 20 mm (0.79 in) tangs (see shelves UL-20-4)
Weight	340.0 kg

Equipment ARM 1060-4-CV	
4 Drawers	vertical, on wheels (see CS-2), incl. 2 Drawers with separators (see CV)
20 Shelves	for type R2/R3 with 20 mm (0.79 in) tangs (see shelves UC-20-1)
10 Shelves	for type R2/R3 with 20 mm (0.79 in) tangs (see shelves UL-20-4)
Weight	351.0 kg

#### ARM 1060-5 / -CV for max. tool length = 1060 mm (41.73 in)



1040 x 1240 x 1360 (W x H x D)  
 40.94 x 48.82 x 53.54 (W x H x D)

for Tools Roller Type R2/R3  
 approx. 32.5 m / 52 m (1279.52 in /  
 2047.24 in) Storage capacity



Equipment ARM 1060-5	
5 Drawers	vertical, on wheels (see CS-2)
20 Shelves	for type R2/R3 with 20 mm (0.79 in) tangs (see shelves UC-20-2)
5 Shelves	for type R2/R3 with 20 mm (0.79 in) tangs (see shelves UL-20-4)
Weight	400.0 kg

Equipment ARM 1060-5-CV	
5 Drawers	vertical, on wheels (see CS-2), incl. 3 Drawers with separators (see CV)
30 Shelves	for type R2/R3 with 20 mm (0.79 in) tangs (see shelves UC-20-1)
10 Shelves	for type R2/R3 with 20 mm (0.79 in) tangs (see shelves UL-20-4)
Weight	490.0 kg

## ROLLERI ACCESSORIES

### Tool Cabinets



#### ARM 1060-4-T / -CV for max. tool length = 1060 mm (41.73 in)



850 x 1240 x 1360 (W x H x D)  
 33.46 x 48.82 x 53.54 (W x H x D)

for tools Roller Type R2/R3  
 approx. 20.8 m / 31.2 m (818.89 in /  
 1228.34 in) Storage capacity



Equipment ARM 1060-4-T	
4 Drawers	vertical, on wheels (see CS-2)
8 Shelves	for type R2/R3 with 13 mm (0.51 in) tangs (see shelves UL-13-4)
8 Shelves	for type R2/R3 (see shelves UT-4)
Weight	383.0 kg

Equipment ARM 1060-4-T-CV	
4 Drawers	vertical, on wheels (see CS-2), incl. 2 Drawers with separators (see CV)
16 Shelves	for type R2/R3 with 13 mm (0.51 in) tangs (see shelves UC-13-1)
8 Shelves	for type R2/R3 (see shelves UT-4)
Weight	360.0 kg

#### ARM 1060-5-T / -CV for max. tool length = 1060 mm (41.73 in)



1040 x 1240 x 1360 (W x H x D)  
 40.94 x 48.82 x 53.54 (W x H x D)

for tools Roller Type R2/R3  
 approx. 26 m / 41.6 m (1023.62 in /  
 1637.79 in) Storage capacity



Equipment ARM 1060-5-T	
5 Drawers	vertical, on wheels (see CS-2)
10 Shelves	for type R2/R3 with 13 mm (0.51 in) tangs (see shelves UL-13-4)
10 Shelves	for type R2/R3 (see shelves UT-4)
Weight	447.0 kg

Equipment ARM 1060-5-T-CV	
5 Drawers	vertical, on wheels (see CS-2), incl. 3 Drawers with separators (see CV)
24 Shelves	for type R2/R3 with 13 mm (0.51 in) tangs (see shelves UC-13-1)
8 Shelves	for type R2/R3 (see shelves UT-4)
Weight	500.0 kg

#### UC-Shelves

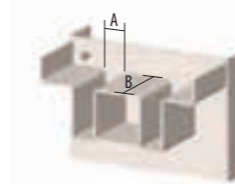

Model	L mm (in)	A mm (in)	B mm (in)	Weight
UC-13-1	125 (4.92)	13 (0.51)	76 (2.99)	0.5 kg
UC-13-2	250 (9.84)	13 (0.51)	232 (9.13)	1.0 kg
UC-20-1	125 (4.92)	20 (0.79)	76 (2.99)	0.5 kg
UC-20-2	250 (9.84)	20 (0.79)	232 (9.13)	1.0 kg

2 pieces

#### UT-Shelves



Model	L (mm)	L (in)	Weight
UT-1	270	10.63	1.4 kg
UT-2	580	22.83	3.2 kg
UT-3	1050	41.34	5.8 kg
UT-4	1360	53.54	7.5 kg

enough room for punches with safety pins

#### UL-Shelves

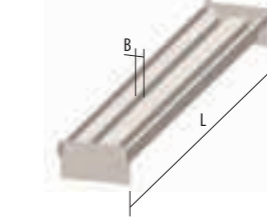

Model	L mm (in)	B mm (in)	Weight
UL-13-1	270 (10.63)	13 (0.51)	1.2 kg
UL-13-2	580 (22.83)	13 (0.51)	2.5 kg
UL-13-3	1050 (41.34)	13 (0.51)	4.6 kg
UL-13-4	1360 (53.54)	13 (0.51)	6.0 kg
UL-20-1	270 (10.63)	20 (0.79)	1.4 kg
UL-20-2	580 (22.83)	20 (0.79)	3.2 kg
UL-20-3	1050 (41.34)	20 (0.79)	5.8 kg
UL-20-4	1360 (53.54)	20 (0.79)	7.5 kg

#### UV-Shelves

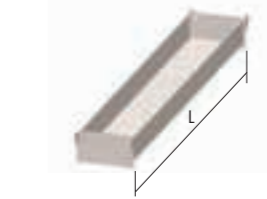

Model	L (mm)	L (in)	Weight
UV-1	270	10.63	1.0 kg
UV-2	580	22.83	2.0 kg
UV-3	1050	41.34	4.3 kg
UV-4	1360	53.54	5.5 kg

#### CS-Drawers



Model	T mm (in)	L mm (in)	Weight
CS-1	1050 (41.34)	856 (33.70)	22.0 kg
CS-2	1360 (53.54)	1166 (45.91)	25.0 kg

#### CV-Dividers

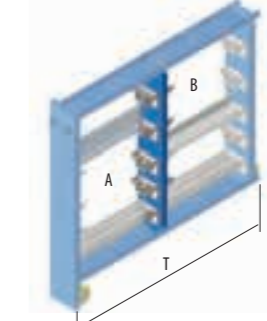

Model	T mm (in)	A mm (in)	B mm (in)	Weight
CV-1	1050 (41.34)	580 (22.83)	270 (10.63)	7.0 kg
CV-2	1360 (53.54)	580 (22.83)	580 (22.83)	7.0 kg

## ROLLERI ACCESSORIES

### Tool Trolley

#### Our Advantages – Your Convenience

- faster access
- robust construction
- clear and tidy storage
- visibility of tools

#### Tool Trolleys

Model	Content	Tool System	Weight
A Trolley	30 Shelves	for R1 tools	108.0 kg
T Trolley	21 Shelves	for R2 tools	175.0 kg
B Trolley	21 Shelves	for R3 tools	135.0 kg



#### Rolleri Videos

Secure storage and mobility:  
[www.rolleritools.com/videos/tool-trolley](http://www.rolleritools.com/videos/tool-trolley)



## ROLLERI ACCESSORIES

### Squaring Arms

#### Our Advantages – Your Convenience

- easy and fast securing
- precise and flexible adjustability
- adjustable angle stop
- mountable on all dies
- ideal for long, and thin sheet metals



#### Rolleri Videos

Magnetic Squaring Arms :  
[www.rolleritools.com/videos/squaring-arms](http://www.rolleritools.com/videos/squaring-arms)



#### MSA – magnetic

MSA.D (right)	per piece	1.4 kg
MSA.S (left)	per piece	1.4 kg

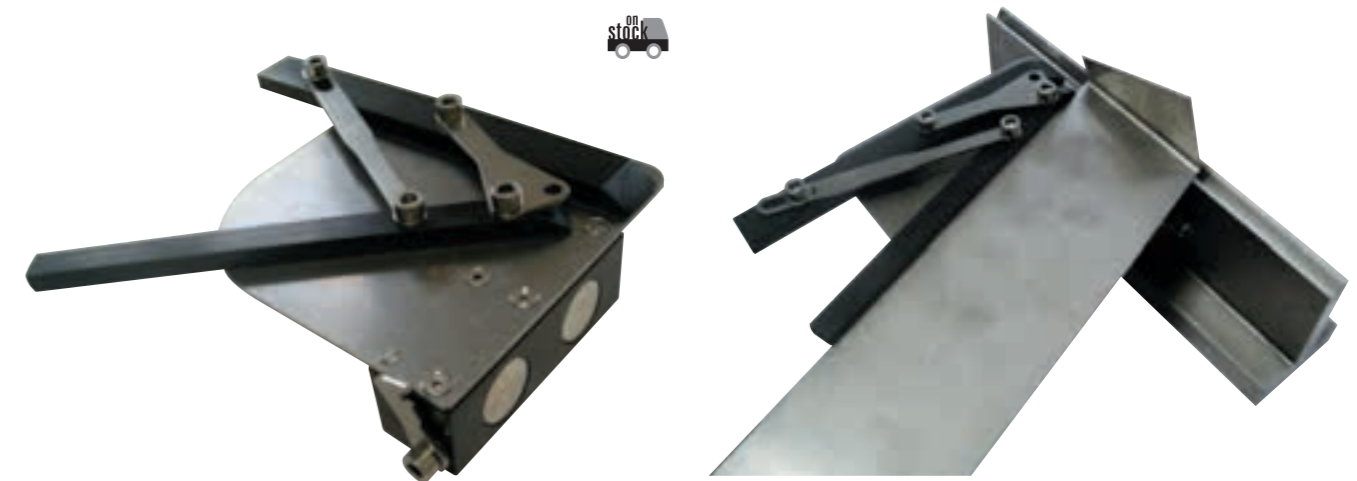

## Bending Box

### Bending Box

per piece 1.6 kg



#### AS

per piece 3.5 kg

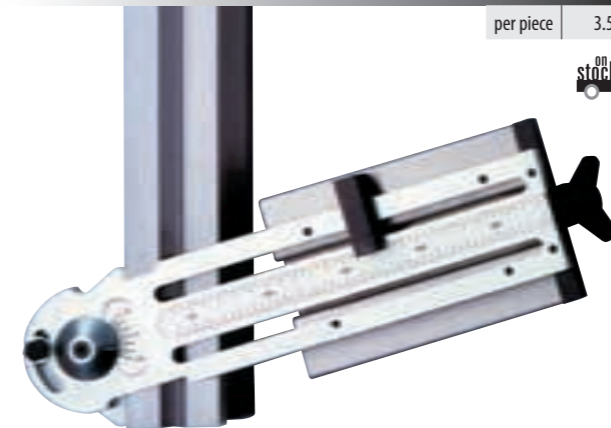

Give us a call for more information!

## ROLLERI ACCESSORIES

### Supporting Arms and Back Gauge

#### RIF-Supporting Arm

Model	Length mm (in)		Weight
RIF500	500	(19.68)	7.0 kg
RIF1000	1000	(39.37)	12.0 kg
RIF1500	1500	(59.05)	17.0 kg



- for secure support for high volume sheet metals
- greater surface guarantees a trouble-free support for sheet metals
- easy handling

#### RP-Back Gauge

Model	Weight
RP500A	8.0 kg
RP500B	8.0 kg

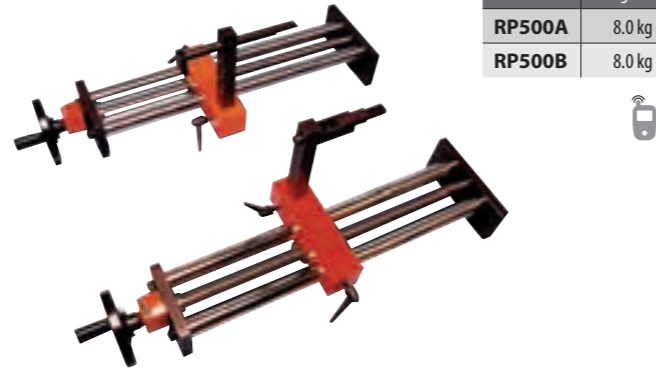

- ensures for the correct positioning of tools on the press brake and secures herewith the exact border distance.
- fast and exact repeatability
- easy handling

#### AS FIX

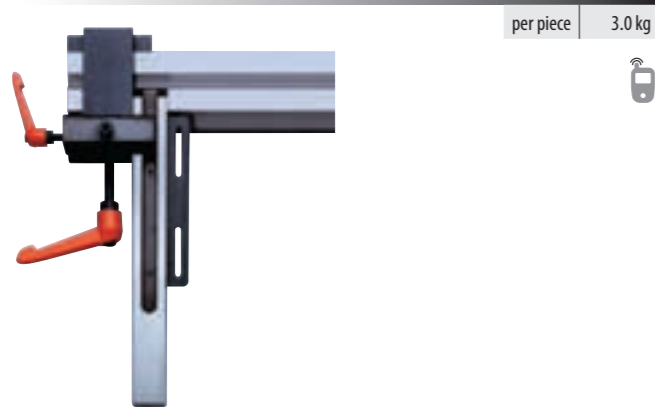

per piece 3.0 kg

## Shear Blades

We manufacture in our company over more than 20 years shear blades.

High-quality steels are finished according to your specifications.

Please provide us with the following information:

- What material are you cutting with your machines: Steel, Stainless Steel, Aluminium, etc.
- How thick is the material in diameter?
- How often to you use your cutting machine? (per hour, day, week)
- How many upper and lower shear blades are needed?

New production and retrofitting service: fast, economic, precise!

## ROLLERI SHEAR BLADES

### Shear Blades



#### Our Advantages – Your Convenience

- own production
- custom production
- depending on the cutting material
- high quality Materials
- 4-, 2- or 1-sharp
- with threaded holes or bilateral reduction
- hardened according to your specifications and request



available sizes mm (in)				
50 x 10 (1.97 x 0.39)	55 x 12 (2.17 x 0.47)	60 x 12 (2.36 x 0.47)	65 x 13 (2.56 x 0.51)	70 x 13 (2.76 x 0.51)
50 x 11 (1.97 x 0.43)	55 x 13 (2.17 x 0.51)	60 x 13 (2.36 x 0.51)	65 x 14 (2.56 x 0.55)	70 x 14 (2.76 x 0.55)
50 x 12 (1.97 x 0.47)	55 x 14 (2.17 x 0.55)	60 x 14 (2.36 x 0.55)	65 x 15 (2.56 x 0.59)	70 x 15 (2.76 x 0.59)
50 x 13 (1.97 x 0.51)	55 x 15 (2.17 x 0.59)	60 x 15 (2.36 x 0.59)	65 x 16 (2.56 x 0.63)	70 x 16 (2.76 x 0.63)
50 x 14 (1.97 x 0.55)	55 x 16 (2.17 x 0.63)	60 x 16 (2.36 x 0.63)	65 x 17 (2.56 x 0.67)	70 x 17 (2.76 x 0.67)
50 x 15 (1.97 x 0.59)	55 x 17 (2.17 x 0.67)	60 x 17 (2.36 x 0.67)	65 x 18 (2.56 x 0.71)	70 x 18 (2.76 x 0.71)
	55 x 18 (2.17 x 0.71)	60 x 18 (2.36 x 0.71)	65 x 19 (2.56 x 0.75)	70 x 19 (2.76 x 0.75)
	55 x 19 (2.17 x 0.75)	60 x 19 (2.36 x 0.75)	65 x 20 (2.56 x 0.79)	70 x 20 (2.76 x 0.79)
	55 x 20 (2.17 x 0.79)	60 x 20 (2.36 x 0.79)		

available sizes mm (in)				
75 x 15 (2.95 x 0.59)	80 x 16 (3.15 x 0.63)	85 x 18 (3.35 x 0.71)	90 x 20 (3.54 x 0.79)	100 x 20 (3.94 x 0.79)
75 x 16 (2.95 x 0.63)	80 x 18 (3.15 x 0.71)	85 x 19 (3.35 x 0.75)	90 x 21 (3.54 x 0.83)	100 x 22 (3.94 x 0.87)
75 x 17 (2.95 x 0.67)	80 x 19 (3.15 x 0.75)	85 x 20 (3.35 x 0.79)	90 x 22 (3.54 x 0.87)	100 x 25 (3.94 x 0.98)
75 x 18 (2.95 x 0.71)	80 x 20 (3.15 x 0.79)	85 x 21 (3.35 x 0.83)	90 x 23 (3.54 x 0.91)	100 x 26 (3.94 x 1.02)
75 x 19 (2.95 x 0.75)	80 x 21 (3.15 x 0.83)	85 x 22 (3.35 x 0.87)	90 x 24 (3.54 x 0.94)	100 x 27 (3.94 x 1.06)
75 x 20 (2.95 x 0.79)	80 x 22 (3.15 x 0.87)	85 x 23 (3.35 x 0.91)	90 x 25 (3.54 x 0.98)	100 x 28 (3.94 x 1.10)
75 x 21 (2.95 x 0.83)	80 x 23 (3.15 x 0.91)	85 x 24 (3.35 x 0.94)		100 x 29 (3.94 x 1.14)
75 x 22 (2.95 x 0.87)	80 x 24 (3.15 x 0.94)	85 x 25 (3.35 x 0.98)		100 x 30 (3.94 x 1.18)
75 x 23 (2.95 x 0.91)	80 x 25 (3.15 x 0.98)			
75 x 24 (2.95 x 0.94)				
75 x 25 (2.95 x 0.98)				

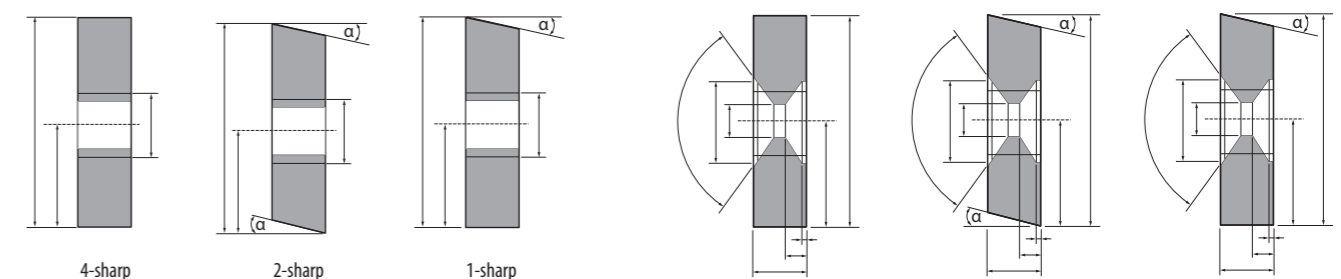
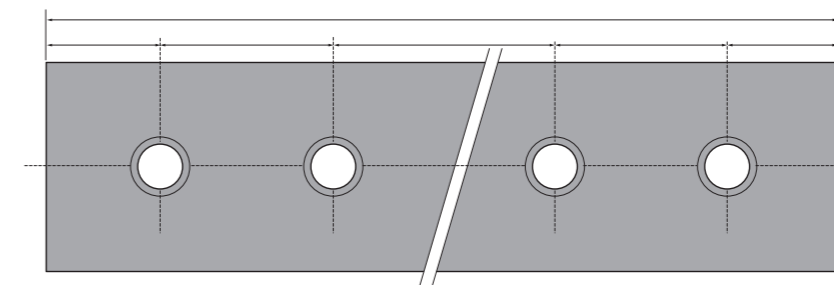

**Press Force Table**

The press force table is based on the press force caliper and is very useful to those who deal with sheet metal profiles. It can assist you from the projection of profiles, to technical construction, to the buying of tools, and to the finished profile from the press brake machine.

In the first left column the thickness of the sheet metal is noted as (S). In the three first lines you can find the die width (V), the minimum boarder (B), and the ideal inner profile radius (Ri).

By crossing the thickness with the die width, you will find the necessary press force per meter. Furthermore, depicted are the span of 5 different die widths. The correction factors are found below in the table.

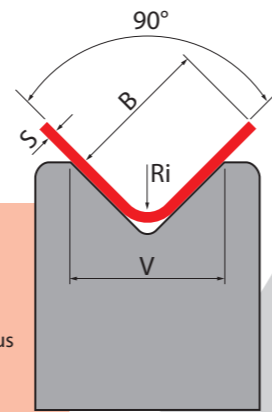

S = Thickness  
V = Die Width  
B = Min. Boarder  
Ri = Inner Profile Radius

		420 N/mm <sup>2</sup>																			
S (mm)		4	5	6	8	10	12	16	20	25	32	40	50	63	80	100	125	160	200	250	V
		3.0	3.5	4.0	5.5	6.5	8.0	10.5	13.0	16.5	21.0	26.0	32.5	41.0	52.0	65.0	81.5	104.0	130.0	163.0	B
		0,5	0,7	0,8	1,0	1,3	1,5	2,0	2,5	3,2	4,4	5,0	6,5	8,0	10,0	12,0	15,0	20,0	25,0	37,0	Ri
0.6		60	50	30	20																
0.8		120	90	70	50	40															
1.0			150	110	80	60	50														
1.2				180	120	90	70	50													
1.5					210	150	120	80	60												
2.0						300	230	160	120	90											
2.5							390	270	200	140	110										
3.0								430	310	230	160	120									
4.0									600	440	320	230	180								
5.0										760	540	390	290	220							
6.0											850	620	450	330	250						
8.0												1210	880	700	460	350					
10.0													1510	1090	790	580	440				
12.0														1730	1240	910	660	500			
15.0															2130	1550	1130	810	620		
20.0																3020	2200	1580	1150	890	
25.0																	3780	2690	1970	1440	

F  
kN/m

30°	B x 1.6	R=200 N/mm <sup>2</sup>	r x 0.8	Al
60°	B x 1.1			
90°	B x 1.0	R=420 N/mm <sup>2</sup>	r x 1.0	Fe
120°	B x 0.9			
150°	B x 0.7	R=700 N/mm <sup>2</sup>	r x 1.4	INOX

[www.rolleritools.com](http://www.rolleritools.com)

Visit us on our website and take advantage of:

- drawings 1:1 format available
- extra information and tips
- helpful videos and application examples
- easy website browsing



**Copyright:** The use of Roller Publications and national adoptions of Roller Publications is subject to the user's acceptance of Roller's terms of use and conditions of copyright for Roller publications, as set out below.

All Roller Publications and national adoptions thereof are protected by copyright. Therefore and unless otherwise specified, no part of an Roller Publication or a national adoption thereof may be reproduced or utilized in any form or by any means, electronic or mechanical, including photocopying, microfilm, and scanning, without permission in writing from the publisher.





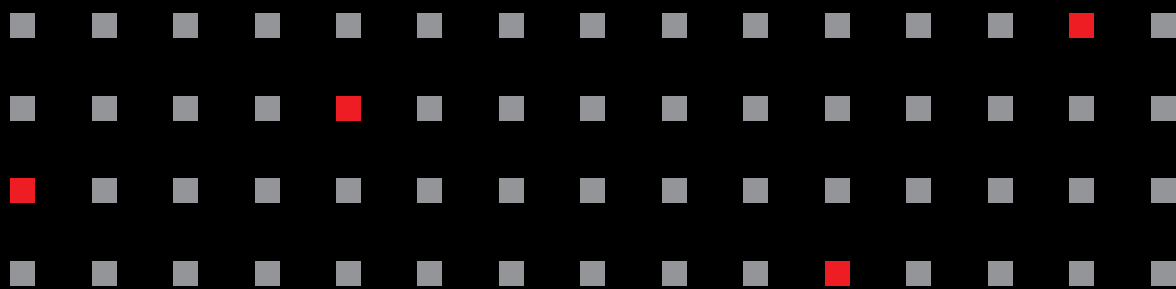

[www.rolleritools.com](http://www.rolleritools.com)



**ROLLERI®**  
**PROFESSIONAL  
BENDING**

**Rolleri S.p.A.**

Via Artigiani Cabina · 29020 Vigolzone (PC) – Italia

Tel. +39 05 23 87 09 05

Fax +39 05 23 87 90 30

E-Mail [sales@rolleri.it](mailto:sales@rolleri.it)

Web [www.rolleri.it](http://www.rolleri.it)